

Grizzly *Industrial, Inc.*®

Model G0613/G0614 Swivel Mast Metal Cutting Bandsaw OWNER'S MANUAL



COPYRIGHT © NOVEMBER, 2006 BY GRIZZLY INDUSTRIAL, INC. REVISED DECEMBER, 2007.

**WARNING: NO PORTION OF THIS MANUAL MAY BE REPRODUCED IN ANY SHAPE
OR FORM WITHOUT THE WRITTEN APPROVAL OF GRIZZLY INDUSTRIAL, INC.**

#CR8638 PRINTED IN TAIWAN

 **WARNING!**

This manual provides critical safety instructions on the proper setup, operation, maintenance and service of this machine/equipment.

Failure to read, understand and follow the instructions given in this manual may result in serious personal injury, including amputation, electrocution or death.

The owner of this machine/equipment is solely responsible for its safe use. This responsibility includes but is not limited to proper installation in a safe environment, personnel training and usage authorization, proper inspection and maintenance, manual availability and comprehension, application of safety devices, blade/cutter integrity, and the usage of personal protective equipment.

The manufacturer will not be held liable for injury or property damage from negligence, improper training, machine modifications or misuse.

 **WARNING!**

Some dust created by power sanding, sawing, grinding, drilling, and other construction activities contains chemicals known to the State of California to cause cancer, birth defects or other reproductive harm. Some examples of these chemicals are:

- **Lead from lead-based paints.**
- **Crystalline silica from bricks, cement and other masonry products.**
- **Arsenic and chromium from chemically-treated lumber.**

Your risk from these exposures varies, depending on how often you do this type of work. To reduce your exposure to these chemicals: Work in a well ventilated area, and work with approved safety equipment, such as those dust masks that are specially designed to filter out microscopic particles.

Table of Contents

INTRODUCTION	2	SECTION 5: ACCESSORIES	27
Foreword	2	SECTION 6: MAINTENANCE	29
Contact Info	2	Schedule	29
Machine Data Sheet	3	Cleaning	29
Machine Data Sheet	5	Lubrication	29
Identification	7	SECTION 7: SERVICE	30
Control Panel	8	Troubleshooting	30
SECTION 1: SAFETY	9	Blade Change	32
Safety Instructions for Machinery	9	Blade Tension	33
Additional Safety Instructions for Bandsaws 11		Blade Guides (G0613)	34
SECTION 2: CIRCUIT REQUIREMENTS	12	Blade Guides (G0614)	36
110/220V Single-Phase (G0613)	12	Swivel Stops	38
220V 3-Phase (G0614)	13	Feed Stop	39
SECTION 3: Setup	14	Feed Auto Stop	39
Setup Safety	14	Blade-to-Vise Squareness	40
Items Needed for Setup	14	Electrical Components (G0613)	41
Unpacking	14	Electrical Components (G0614)	42
Inventory	15	G0613 220V Single-Phase Wiring Diagram 46	
Clean Up	16	G0614 220V Three-Phase Wiring Diagram 47	
Site Considerations	16	SECTION 8: PARTS	48
Cabinet Assembly	17	Headstock and Bow Breakdown (G0613) ...	48
Mounting to Shop Floor	17	Headstock and Bow Breakdown (G0614) ...	50
Cutting Fluid System	18	Base Breakdown (G0613)	52
Recommended Adjustments	19	Base Breakdown (G0614)	54
Test Run	19	Electrical Box Breakdown (G0613)	56
SECTION 4: OPERATIONS	20	Electrical Box Breakdown (G0614)	57
Operation Safety	20	Cabinet and Gearbox Breakdown (G0613	
Cutting Angle	20	& G01614)	59
Workstop	21	Labels and Placement	61
Vise	21	WARRANTY AND RETURNS	62
Blade Selection	23		
Blade Speed	23		
Splash Tray	24		
Using Blade Guides	24		
Setting Feed Rate	25		
Cutting Fluid Tips	26		
Operation Tips	26		

INTRODUCTION

Foreword

We are proud to offer the Model G0613/14 Swivel Mast Metal Cutting Bandsaw. This machine is part of a growing Grizzly family of fine metal-working machinery. When used according to the guidelines set forth in this manual, you can expect years of trouble-free, enjoyable operation and proof of Grizzly's commitment to customer satisfaction.

We are pleased to provide this manual with the Model G0613/14. It was written to guide you through assembly, review safety considerations, and cover general operating procedures. It represents our effort to produce the best documentation possible.

The specifications, drawings, and photographs illustrated in this manual represent the Model G0613/14 as supplied when the manual was prepared. However, owing to Grizzly's policy of continuous improvement, changes may be made at any time with no obligation on the part of Grizzly. For your convenience, we always keep current Grizzly manuals available on our website at **www.grizzly.com**. Any updates to your machine will be reflected in these manuals as soon as they are complete. Visit our site often to check for the latest updates to this manual!

Contact Info

If you have any comments regarding this manual, please write to us at the address below:

Grizzly Industrial, Inc.
c/o Technical Documentation Manager
P.O. Box 2069
Bellingham, WA 98227-2069
Email: manuals@grizzly.com

We stand behind our machines. If you have any service questions or parts requests, please call or write us at the location listed below.

Grizzly Industrial, Inc.
1203 Lycoming Mall Circle
Muncy, PA 17756
Phone: (570) 546-9663
Fax: (800) 438-5901
E-Mail: techsupport@grizzly.com
Web Site: <http://www.grizzly.com>





MACHINE DATA SHEET

Customer Service #: (570) 546-9663 • To Order Call: (800) 523-4777 • Fax #: (800) 438-5901

MODEL G0613 SWIVEL MAST METAL-CUTTING BANDSAW

Product Dimensions:

Floor to Table Height 35⁵/₈"
 Overall Dimensions 63"L x 29³/₄"W x 66"H
 Approximate Net Weight 418 lbs.

Shipping Dimensions:

Overall Dimensions (Crate 1, Machine) 26¹/₂"L x 50¹/₂"W x 34⁹/₁₆"H
 Crate Dimensions (Crate 2, Cabinet) 25¹³/₁₆"L x 6³/₈"W x 24¹³/₁₆"H
 Type Wood Slat Crate
 Approximate Shipping Weight (Crate 1, Machine) 451 lbs.
 Approximate Shipping Weight (Crate 2, Cabinet) 59.5 lbs.

Electrical:

Controls Centralized Control Panel Operation
 Switch Pushbutton
 Switch Voltage 110V/220V
 Recommended Cord Gauge Three-Wire, 14 AWG
 Recommended Breaker Size 20 A

Motors:

Main

Type TEFC Capacitor Start Induction
 Horsepower 1 HP
 Voltage (Prewired 110V) 110V/220V
 Phase Single
 Amps 15.4A/7.7A
 Speed 3450 RPM
 Cycle 60 Hz
 Number of Speeds 1
 Blade Drive Sealed Worm Gear
 Bearings Shielded and Lubricated

Pump

Type Sealed/Waterproof
 Horsepower 1/8 HP
 Voltage (Prewired 110V) 110V/220V
 Phase Single
 Amps 0.9A/0.45A
 Speed 3450 RPM
 Cycle 60 Hz
 Bearings Shielded and Lubricated



Main Specifications:

Operation Info

Blade Speeds.....	314 FPM
Blade Size.....	3/4" x 82"
Head Swivel	0° to 60°

Cutting capacities:

0°, round	7"
0°, rectangular.....	5" x 8 1/4"
±45°, round	4 1/4"
±45°, rectangular	4" x 4 1/4"
+60°, round	2"
+60°, rectangular	2 3/4" x 2"
Miter cutting capacity	0° to 60°

Other Specifications:

Country of Origin.....	Taiwan
Warranty.....	1 Year
Serial Number Location	Grizzly ID Label

Features:

- Swivel Base with Degree Scale
- Centralized Control Panel
- Heavy-duty All Steel, One Piece Base
- Adjustable Hydraulic Down Feed
- Extra Clamping Capacity Vise with Lever Lock
- Quick Release Vise
- Tooth Selection Chart
- Built-in Cutting fluid System
- Automatic Shut Off
- Adjustable Blade Guide System Blade Wheels Have Heavy-duty Ball Bearings





MACHINE DATA SHEET

Customer Service #: (570) 546-9663 • To Order Call: (800) 523-4777 • Fax #: (800) 438-5901

MODEL G0614 SWIVEL MAST METAL-CUTTING BANDSAW

Product Dimensions:

Floor to table height 35⁵/₈"
 Overall dimensions 68"L x 26⁷/₈"W x 69"H
 Approximate Net Weight 506 lbs.

Shipping Dimensions:

Overall Dimensions (Crate 1, Machine) 28¹/₈"L x 53"W x 52"H
 Crate Dimensions (Crate 2, Cabinet) 34¹/₂"L x 6³/₈"W x 24¹/₂"H
 Type Wood Slat Crate
 Approximate Shipping Weight (Crate 1, Machine) 550 lbs.
 Approximate Shipping Weight (Crate 2, Cabinet) 72.7 lbs.

Electrical:

Controls Centralized Control Panel Operation
 Switch Pushbutton
 Switch Voltage 220V, 3-Phase
 Recommended Cord Gauge 4-Wire, 14 AWG
 Recommended Breaker Size 15A

Motors:

Main

Type TEFC
 Horsepower 1¹/₂ HP
 Voltage 220V
 Phase 3-Phase
 Amps 3A
 Speed 1725, 3450 RPM
 Cycle 60 Hz
 Number of Speeds 2
 Blade Drive Sealed Worm Gear
 Bearings Shielded and Lubricated

Pump

Type Sealed/Waterproof
 Horsepower 1/8 HP
 Voltage 220V
 Phase 3-Phase
 Amps 0.65
 Speed 3450 RPM
 Cycle 60 Hz
 Bearings Shielded and Lubricated



Main Specifications:

Operation Info

Blade Speeds.....170, 341 FPM
Blade Size..... 1" x 97⁵/₈"
Head Swivel 0° to 60°

Cutting capacities:

0°, round 8³/₄"
0°, rectangular..... 6" x 9¹/₂"
±45°, round 5"
±45°, rectangular 5" x 5"
+60°, round 2³/₄"
+60°, rectangular 2³/₄" x 2³/₄"
Miter cutting capacity 0° to 60°

Other Specifications:

Country of Origin.....Taiwan
Warranty.....1 Year
Serial Number LocationGrizzly ID Label

Features:

- Swivel Base with Degree Scale
- Two-Speed Motor
- Centralized Control Panel
- Heavy-duty All Steel, One Piece Base
- Adjustable Hydraulic Down Feed
- Extra Clamping Capacity Vise with Lever Lock
- Quick Release Vise
- Tooth Selection Chart
- Built-in Cutting fluid System
- Automatic Shut Off
- Adjustable Blade Guide System Blade Wheels Have Heavy-duty Ball Bearings and Carbide Rub Blocks



Identification

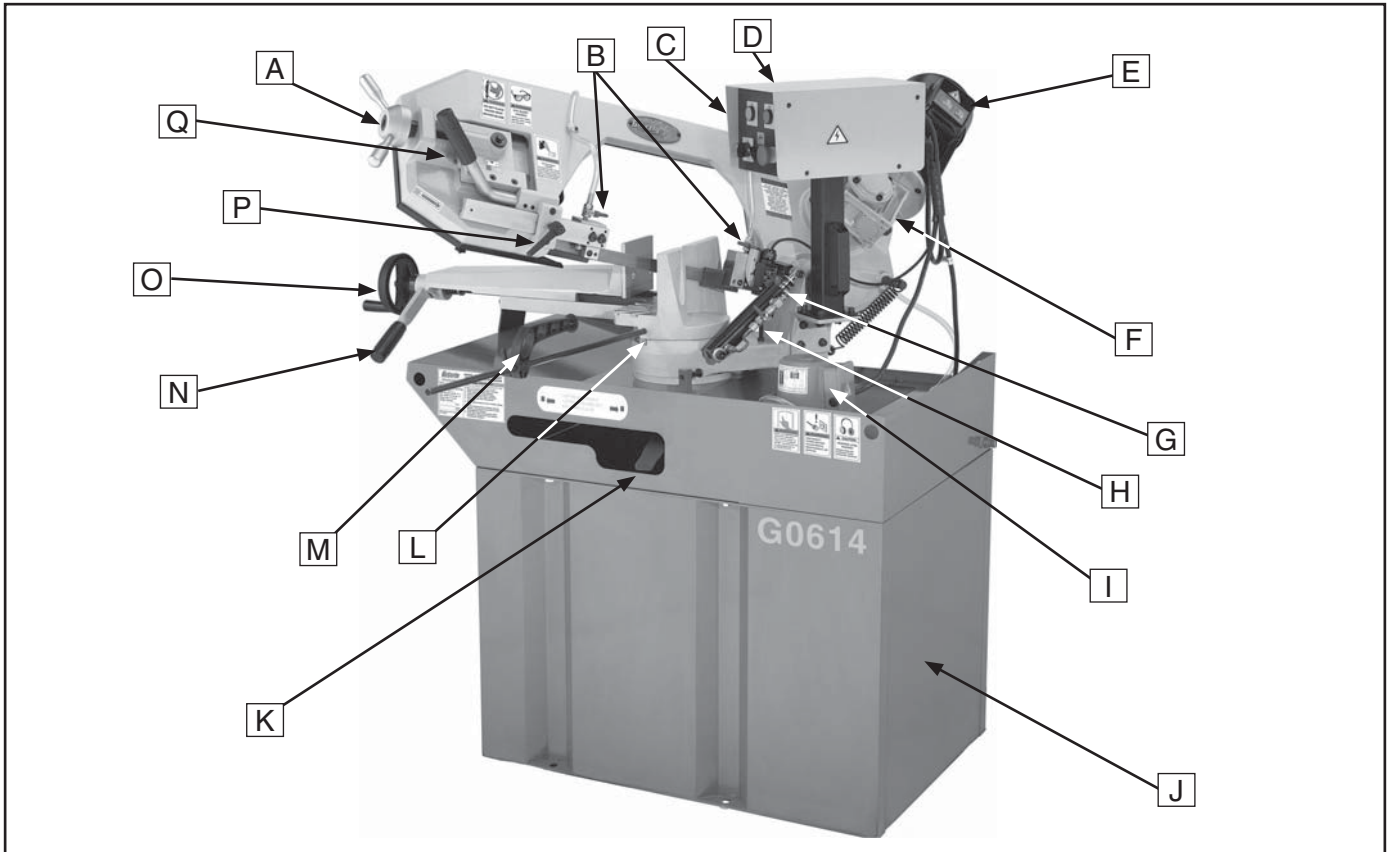

Figure 1. G0613/14 Machine Identification.

- | | |
|-------------------------------------|---|
| A. Blade Tension Handwheel | J. Main Support Cabinet |
| B. Cutting Fluid Flow Valves | K. Headstock Swivel Lock Lever |
| C. Control Panel | L. Swivel Degree Scale |
| D. Main Electrical Box | M. Work Stop |
| E. Bandsaw Motor | N. Vise Lock Lever |
| F. Worm Drive Gearbox | O. Vise Clamp Handwheel |
| G. Feed Rate Control Knob | P. Blade Guide Position Lock Lever |
| H. Feed ON/OFF Valve | Q. Headstock Lift Arm and Handle |
| I. Cutting Fluid Pump | |



Control Panel

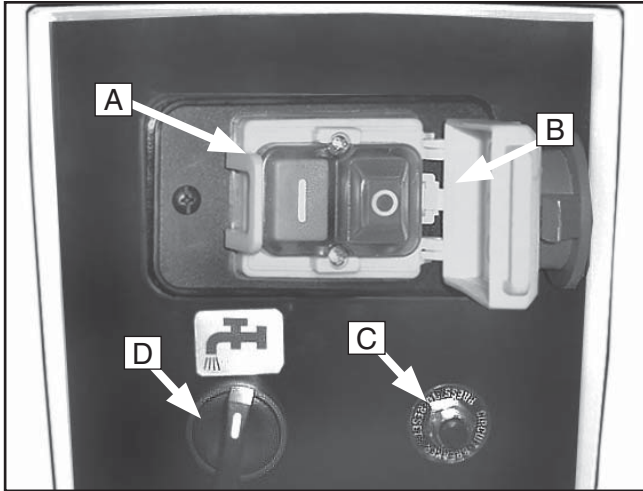

Figure 2. G0613 control panel.

A. ON/OFF Push Button Switch: When the cover is open, it allows access to the normal-operation ON/OFF pushbutton switch that is used to start and stop the bandsaw.

B. EMERGENCY Stop and Anti-Start Lockout Cover: When the cover is closed but not latched shut, it serves as an easy-to-find EMERGENCY STOP button with anti-start lockout. If pushed in an emergency situation, the cover pushes the OFF button and then latches shut, preventing accidental machine startup.

Note: Both bandsaws also have an automatic shut-off (limit switch) that turns the saw **OFF** at the completion of the cutting arc.

C. Circuit Breaker: Kills power in the event of high current draw or motor overload.

D. Cutting Fluid Pump Switch: Turns the cutting fluid pump **ON**.

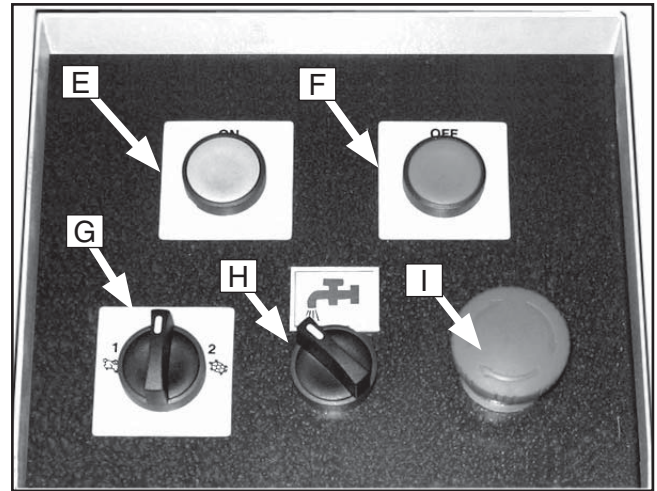

Figure 3. G0614 control panel.

E. ON Button: Turns the motor **ON** and starts the bandsaw.

F. OFF Button: Turns the motor **OFF** and stops the bandsaw.

G. Cutting Speed Switch: Changes the motor speed between 1725 and 3450 RPM, giving two cutting speeds of 170 and 341 FPM.

H. Cutting Fluid Pump Switch: Turns the cutting fluid pump **ON**.

I. EMERGENCY STOP/OFF Button: Kills power to the system and turns the motor **OFF**. Twist the button until it pops out to re-energize the system.



SECTION 1: SAFETY

WARNING

For Your Own Safety, Read Instruction Manual Before Operating this Machine

The purpose of safety symbols is to attract your attention to possible hazardous conditions. This manual uses a series of symbols and signal words which are intended to convey the level of importance of the safety messages. The progression of symbols is described below. Remember that safety messages by themselves do not eliminate danger and are not a substitute for proper accident prevention measures.

 **DANGER** Indicates an imminently hazardous situation which, if not avoided, **WILL** result in death or serious injury.

 **WARNING** Indicates a potentially hazardous situation which, if not avoided, **COULD** result in death or serious injury.

 **CAUTION** Indicates a potentially hazardous situation which, if not avoided, **MAY** result in minor or moderate injury. It may also be used to alert against unsafe practices.

NOTICE This symbol is used to alert the user to useful information about proper operation of the machine.

WARNING

Safety Instructions for Machinery

- 1. READ THROUGH THE ENTIRE MANUAL BEFORE STARTING MACHINERY.** Machinery presents serious injury hazards to untrained users.
- 2. ALWAYS USE ANSI APPROVED SAFETY GLASSES WHEN OPERATING MACHINERY.** Everyday eyeglasses only have impact resistant lenses, they are NOT safety glasses.
- 3. ALWAYS WEAR AN NIOSH APPROVED RESPIRATOR WHEN OPERATING MACHINERY THAT PRODUCES DUST.** Wood dust is a carcinogen and can cause cancer and severe respiratory illnesses.
- 4. ALWAYS USE HEARING PROTECTION WHEN OPERATING MACHINERY.** Machinery noise can cause permanent hearing damage.
- 5. WEAR PROPER APPAREL. DO NOT** wear loose clothing, gloves, neckties, rings, or jewelry which may get caught in moving parts. Wear protective hair covering to contain long hair and wear non-slip footwear.
- 6. NEVER OPERATE MACHINERY WHEN TIRED, OR UNDER THE INFLUENCE OF DRUGS OR ALCOHOL.** Be mentally alert at all times when running machinery.



WARNING

Safety Instructions for Machinery

7. **ONLY ALLOW TRAINED AND PROPERLY SUPERVISED PERSONNEL TO OPERATE MACHINERY.** Make sure operation instructions are safe and clearly understood.
8. **KEEP CHILDREN AND VISITORS AWAY.** Keep all children and visitors a safe distance from the work area.
9. **MAKE WORKSHOP CHILD PROOF.** Use padlocks, master switches, and remove start switch keys.
10. **NEVER LEAVE WHEN MACHINE IS RUNNING.** Turn power **OFF** and allow all moving parts to come to a complete stop before leaving machine unattended.
11. **DO NOT USE IN DANGEROUS ENVIRONMENTS.** DO NOT use machinery in damp, wet locations, or where any flammable or noxious fumes may exist.
12. **KEEP WORK AREA CLEAN AND WELL LIT.** Clutter and dark shadows may cause accidents.
13. **USE A GROUNDED EXTENSION CORD RATED FOR THE MACHINE AMPERAGE.** Undersized cords overheat and lose power. Replace extension cords if they become damaged. DO NOT use extension cords for 220V machinery.
14. **ALWAYS DISCONNECT FROM POWER SOURCE BEFORE SERVICING MACHINERY.** Make sure switch is in OFF position before reconnecting.
15. **MAINTAIN MACHINERY WITH CARE.** Keep blades sharp and clean for best and safest performance. Follow instructions for lubricating and changing accessories.
16. **MAKE SURE GUARDS ARE IN PLACE AND WORK CORRECTLY BEFORE USING MACHINERY.**
17. **REMOVE ADJUSTING KEYS AND WRENCHES.** Make a habit of checking for keys and adjusting wrenches before turning machinery **ON**.
18. **CHECK FOR DAMAGED PARTS BEFORE USING MACHINERY.** Check for binding and alignment of parts, broken parts, part mounting, loose bolts, and any other conditions that may affect machine operation. Repair or replace damaged parts.
19. **USE RECOMMENDED ACCESSORIES.** Refer to the instruction manual for recommended accessories. The use of improper accessories may cause risk of injury.
20. **DO NOT FORCE MACHINERY.** Work at the speed for which the machine or accessory was designed.
21. **SECURE WORKPIECE.** Use clamps or a vise to hold the workpiece when practical. A secured workpiece protects your hands and frees both hands to operate the machine.
22. **DO NOT OVERREACH.** Keep proper footing and balance at all times.
23. **MANY MACHINES WILL EJECT THE WORKPIECE TOWARD THE OPERATOR.** Know and avoid conditions that cause the workpiece to "kickback."
24. **ALWAYS LOCK MOBILE BASES (IF USED) BEFORE OPERATING MACHINERY.**
25. **BE AWARE THAT CERTAIN DUST MAY BE HAZARDOUS** to the respiratory systems of people and animals, especially fine dust. Make sure you know the hazards associated with the type of dust you will be exposed to and always wear a respirator approved for that type of dust.



WARNING

Additional Safety Instructions for Bandsaws

- 1. BLADE CONDITION.** Do not operate with dull, cracked or badly worn blade. Inspect blades for cracks and missing teeth before each use.
- 2. HAND PLACEMENT.** Never position fingers or thumbs in line with the cut. Hands could be crushed in vise or by falling machine components or cut by the blade.
- 3. ENTANGLEMENT HAZARDS.** Do not operate this bandsaw without blade guard in place. Otherwise, loose clothing, jewelry, long hair and work gloves can be drawn into working parts.
- 4. BLADE REPLACEMENT.** When replacing blades, make sure teeth face toward the workpiece. Wear gloves to protect hands and safety glasses to protect eyes.
- 5. WORKPIECE HANDLING.** Always support the workpiece with table, vise, or other support fixture. Flag long pieces to avoid a tripping hazard. Never hold the workpiece with your hands during a cut.
- 6. LOSS OF STABILITY.** Unsupported workpieces may jeopardize machine stability and cause the machine to tip and fall, which could cause serious injury.
- 7. POWER INTERRUPTION.** Unplug machine after power interruption. Machines without magnetic switches can start up after power is restored.
- 8. FIRE HAZARD.** Use EXTREME CAUTION if cutting magnesium. Using the wrong cutting fluid will lead to chip fire and possible explosion.
- 9. CUTTING FLUID SAFETY.** Always follow manufacturer's cutting fluid safety instructions. Pay particular attention to contact, contamination, inhalation, storage and disposal warnings. Spilled cutting fluid is a slipping hazard and a toxicity hazard.
- 10. ATTENTION TO WORK AREA.** Never leave a machine running and unattended. Pay attention to the actions of others in the area to avoid unintended accidents.
- 11. MAINTENANCE/SERVICE.** All inspections, adjustments, and maintenance are to be done with the machine **OFF** and the power disconnected to the machine. Wait for all moving parts to come to a complete stop.
- 12. HEARING PROTECTION & HAZARDS.** Noise generated by blade and workpiece vibration, material handling, and power transmission can cause permanent hearing loss over time and interfere with communication and audible signals. Always wear hearing protection.
- 13. HOT SURFACES.** Due to friction, the workpiece, chips, and some machine components can be hot enough to burn you.

WARNING

No list of safety guidelines can be complete. Every shop environment is different. Like all machines there is danger associated with the Model G0613/14. Accidents are frequently caused by lack of familiarity or failure to pay attention. Use this machine with respect and caution to lessen the possibility of operator injury. If normal safety precautions are overlooked or ignored, serious personal injury may occur.



SECTION 2: CIRCUIT REQUIREMENTS

110/220V Single-Phase (G0613)

⚠️ WARNING

The Model G0613 is prewired for 110V operation. If you plan to use your machine at 220V, you must rewire the motor and install the conversion kit part number P0613264. Refer to the wiring diagram and consult a qualified electrician.

Amperage Draw

The Model G0613 features a 110/220V motor that is prewired for 110V and draws the following amps under maximum load:

Motor Draw at 220V7.7 Amps
Motor Draw at 110V 15.4 Amps

Circuit Requirements

We recommend connecting your machine to a dedicated and grounded circuit that is rated for the amperage given below. Never replace a circuit breaker on an existing circuit with one of higher amperage without consulting a qualified electrician to ensure compliance with wiring codes. **If you are unsure about the wiring codes in your area or you plan to connect your machine to a shared circuit, consult a qualified electrician.**

110V Circuit.....20 Amps
220V Circuit..... 15 Amps

220V Connection

Rewire the motors according to the wiring connection diagram on the inside cover of the motor and pump junction boxes. Refer to **G0613 Single Phase 220V Wiring Diagram** on **Page 46** for general wiring details. Also use the following 220V plug for your machine on a dedicated circuit (see **Figure 4**):

220V Plug & Receptacle6-15

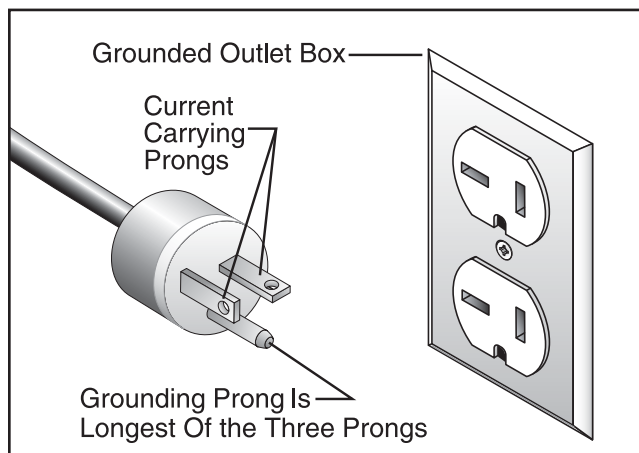
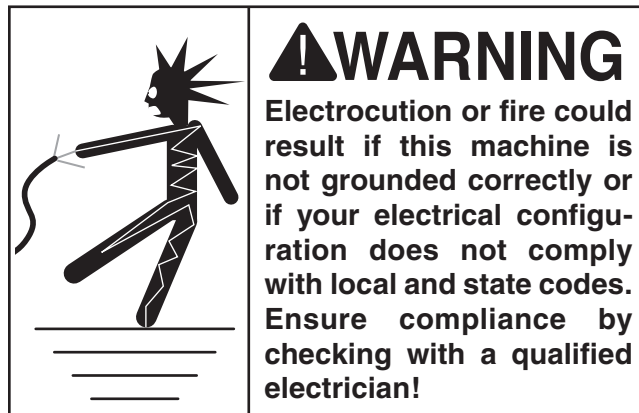

Figure 4. Recommended 220V 6-15 outlet and plug.

Extension Cords

Using extension cords may reduce the life of the motor. Instead, place the machine near a power source. If you must use an extension cord:

- For 110V, use at least a 12 gauge cord that does not exceed 50 feet in length.
- For 220V, use at least a 14 gauge cord that does not exceed 50 feet in length.
- Ensure that the extension cord contains a ground wire and plug pin.



220V 3-Phase (G0614)

! WARNING

Serious personal injury could occur if you connect your machine to the power source before you have completed the setup process. **DO NOT** connect the machine to the power source until instructed to do so.

Amperage Draw

The Model G0614 features a 1.5 HP, 220V, 3-phase motor that draws the following amps under maximum load:

Motor Draw at 220V 5 Amps

Circuit Requirements

We recommend connecting your machine to a dedicated and grounded circuit that is rated for the amperage given below. Never replace a circuit breaker on an existing circuit with one of higher amperage without consulting a qualified electrician to ensure compliance with wiring codes. **If you are unsure about the wiring codes in your area or you plan to connect your machine to a shared circuit, consult a qualified electrician.**

220V 3-Phase Circuit 15 Amps

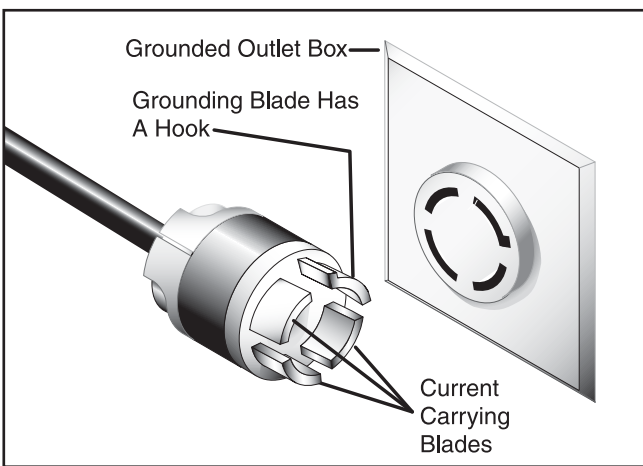
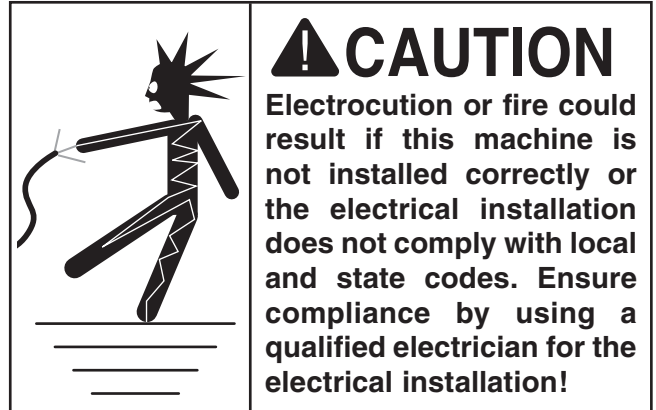

Figure 5. NEMA L15-20R Plug and receptacle.

Grounding

In the event of an electrical short, grounding reduces the risk of electric shock. The grounding wire in the power cord must be properly connected to the grounding prong on the plug; likewise, the outlet must be properly installed and grounded. All electrical connections must be made in accordance with local codes and ordinances.



Extension Cords

We do not recommend using an extension cord for the machine power supply. Instead, locate your machine where you can eliminate the need of an extension cord.

If you find it absolutely necessary to use an extension cord, make sure the extension cord contains a ground wire, and a grounding lug.

Use at least a 10 gauge cord that does not exceed 50 feet in length!



SECTION 3: Setup

Setup Safety

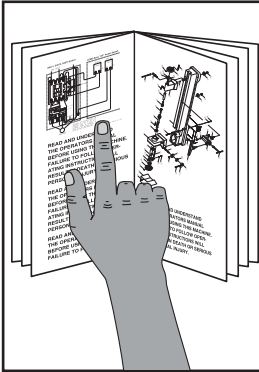

!WARNING
This machine presents serious injury hazards to untrained users. Read through this entire manual to become familiar with the controls and operations before starting the machine!

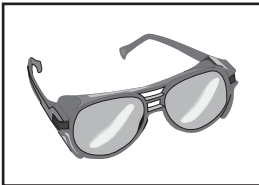

!WARNING
Wear safety glasses during the entire setup process!

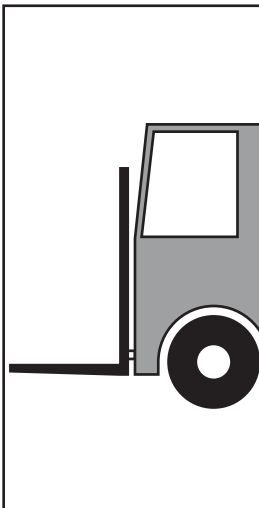

!WARNING
The Model G0613/14 is an extremely heavy machine. Serious personal injury may occur if safe moving methods are not followed. To be safe, you will need assistance and power equipment when moving the shipping crate and removing the machine from the crate.

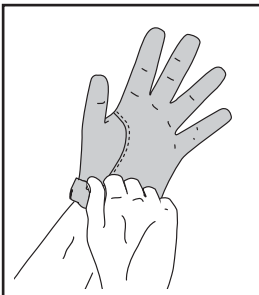

!CAUTION
CUTTING HAZARD!
Blades are sharp! Put on heavy leather gloves when handling a blade or making adjustments near a blade or cutter!

Items Needed for Setup

The following items are needed to complete the setup process, but are not included with your machine:

Description	Qty
• Safety Glasses (for each person)	1
• Solvent Cleaner.....	As Needed
• Shop Towels.....	As Needed
• Mounting Hardware (optional)....	As Needed
• Forklift or Hoist	1
• Cutting Fluid	1 Gallon
• Assistant.....	1

Unpacking

The Model G0613/14 was carefully packed when it left our warehouse. If you discover the machine is damaged after you have signed for delivery, *please immediately call Customer Service at (570) 546-9663 for advise.*

Save the containers and all packing materials for possible inspection by the carrier or its agent. *Otherwise, filing a freight claim can be difficult.*

When you are completely satisfied with the condition of your shipment, you should inventory the contents.



Inventory

After all the parts have been removed from the crate, you should have the following accessories:

Shipping Crate: (Figure 6)	Qty
A. Splash tray (only for G0614)	1
B. Handle	1
C. Work Stop Arm	1
D. Work Stop Lock Lever	1
E. Work Stop Rod	1
F. Hardware	1
—Carriage Screw 5/16-18 X16	8
—Hex Nut 5/16-18	8
—Flat Washer 10mm	4
—Hex Bolt M10-1.5 X 25	4

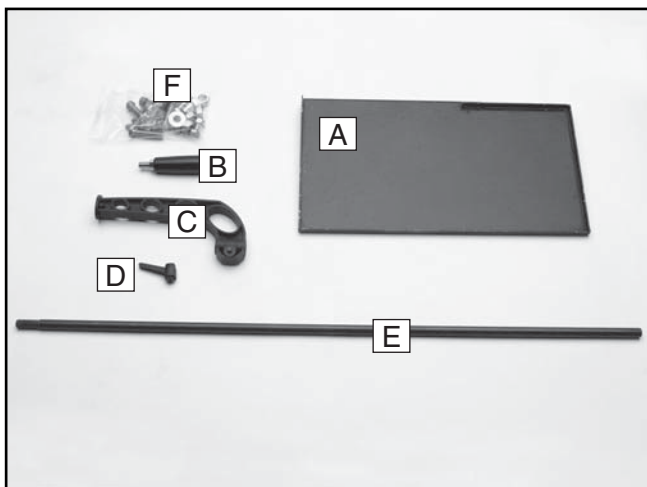

Figure 6. G0613/14 inventory.

In the event that any nonproprietary parts are missing (e.g. a nut or a washer), we would be glad to replace them, or for the sake of expediency, replacements can be obtained at your local hardware store.

NOTICE

Some hardware/fasteners on the inventory list may arrive pre-installed on the machine. Check these locations before assuming that any items from the inventory list are missing.



Clean Up

The unpainted surfaces are coated with a waxy oil to protect them from corrosion during shipment. Remove this protective coating with a solvent cleaner or citrus-based degreaser such as Grizzly's G7895 Degreaser. To clean thoroughly, some parts may need to be removed. **For optimum performance from your machine, make sure you clean all moving parts or sliding contact surfaces that are coated.** Avoid chlorine-based solvents, such as acetone or brake parts cleaner, as they will damage painted surfaces should they come in contact. Always follow the manufacturer's instructions when using any type of cleaning product.

	<p>⚠️ WARNING Gasoline and petroleum products have low flash points and could cause an explosion or fire if used to clean machinery. DO NOT use gasoline or petroleum products to clean the machinery.</p>
--	--

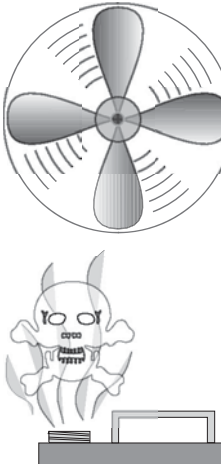
	<p>⚠️ CAUTION Many of the solvents commonly used to clean machinery can be toxic when inhaled or ingested. Lack of ventilation while using these solvents could cause serious personal health risks or fire. Take precautions from this hazard by only using cleaning solvents in a well ventilated area.</p>
---	--

Site Considerations

Floor Load and Working Clearances

Refer to the **Machine Data Sheet** for the weight and footprint specifications of your machine. Some floors may require additional reinforcement to support both the machine and operator.

Consider existing and anticipated needs, size of material to be processed through each machine, and space for auxiliary stands, work tables or other machinery. See **Figure 7** for the minimum working clearances.

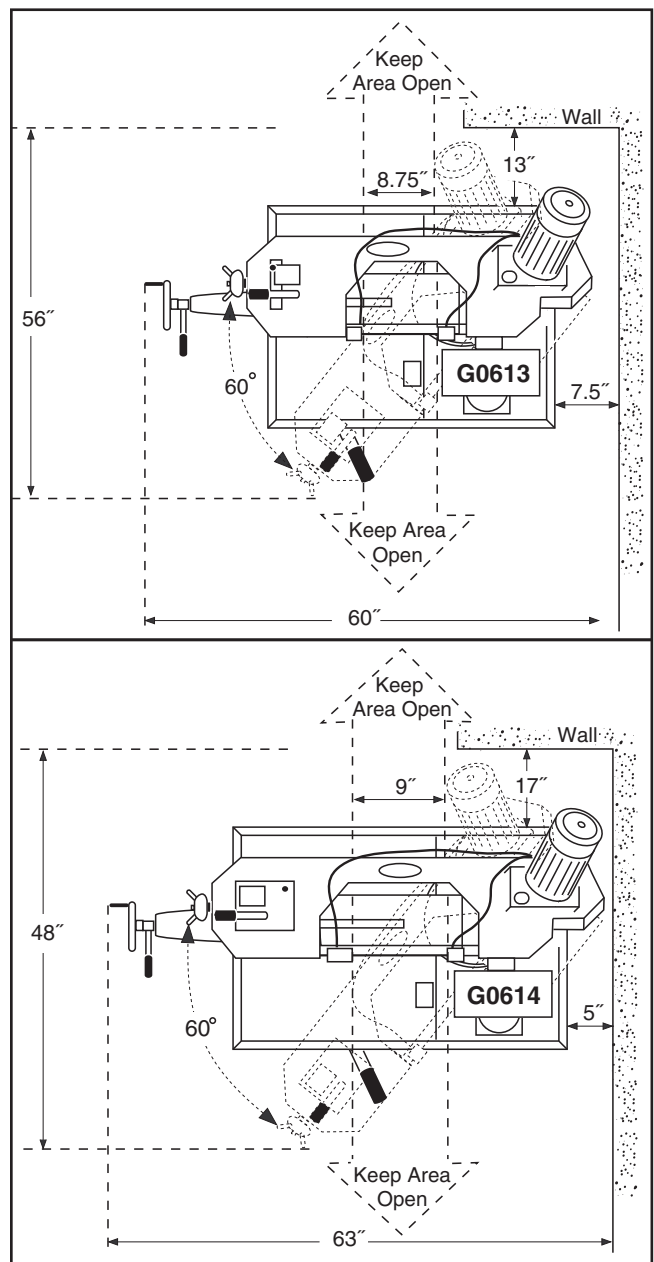

Figure 7. Minimum working clearances.



Cabinet Assembly

To assemble the cabinet:

1. Assemble the four cabinet sides together with the eight M8-1.25 x 16 hex bolts and nuts.
2. Using a hoist and straps that can hold at least 600 lbs. (see **Figure 8**), lower the bandsaw and base onto the top of the cabinet so the swivel lock lever protrudes through the side of the cabinet and the four cabinet mounting holes line up.
3. Secure the bandsaw base to the cabinet with the four M10-1.5 x 35 hex bolts and the flat washers.

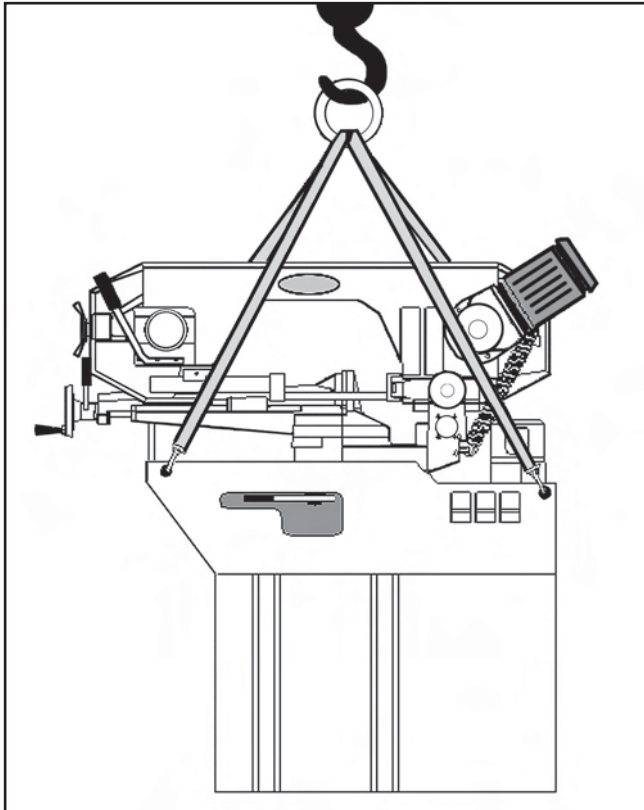
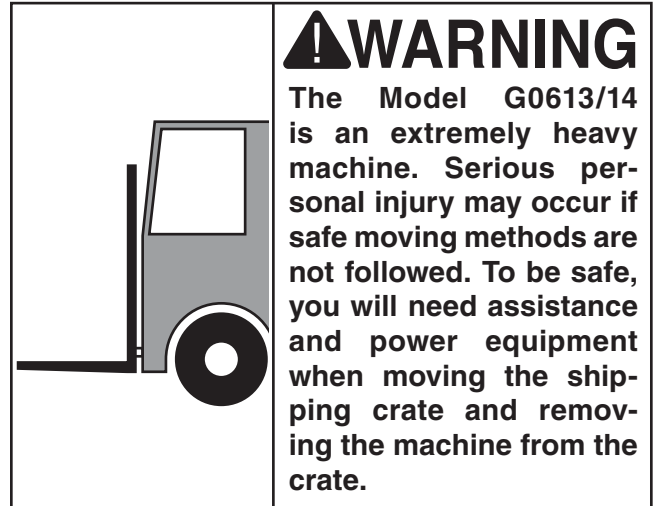

Figure 8. G0613/14 lifting points.



WARNING

The Model G0613/14 is an extremely heavy machine. Serious personal injury may occur if safe moving methods are not followed. To be safe, you will need assistance and power equipment when moving the shipping crate and removing the machine from the crate.

Mounting to Shop Floor

Typical Machine Mounting Options

Although not required, we recommend that you mount your new machine to the floor. Using machine mounts, shown in **Figure 9**, gives the advantage of fast leveling and vibration reduction. Lag shield anchors with lag bolts and anchor studs are two popular methods for anchoring an object to a concrete floor. Because this is an optional step and floor materials may vary, floor mounting hardware is not included. Generally, you can either bolt your machine to the floor or mount it on machine mounts. It may be necessary to level your machine after mounting.

NOTICE

Anchor studs are stronger and more permanent alternatives to lag shield anchors; however, they will stick out of the floor, which may cause a tripping hazard if you decide to move your machine.



Figure 9. Typical options for machine mounting.



Cutting Fluid System

	<p>!WARNING FIRE HAZARD! DO NOT cut magnesium when using oil-water solutions as a cutting fluid! Always use a cutting fluid intended for magnesium. The water in the solution will cause a magnesium-chip fire.</p>
---	---

This bandsaw has a built-in cutting fluid system that extends the life of your bandsaw blades by lowering the temperature of the blade and workpiece.

See **Cutting Fluid** on **Page 26** for additional information.

To use the cutting fluid system:

1. Remove the Phillip head screw and the reservoir screen.
2. Thoroughly clean and remove any foreign material that may have fallen inside the reservoir during shipping and machine use.
3. Fill the reservoir (**Figure 11**) with your chosen cutting fluid solution and replace the screen.

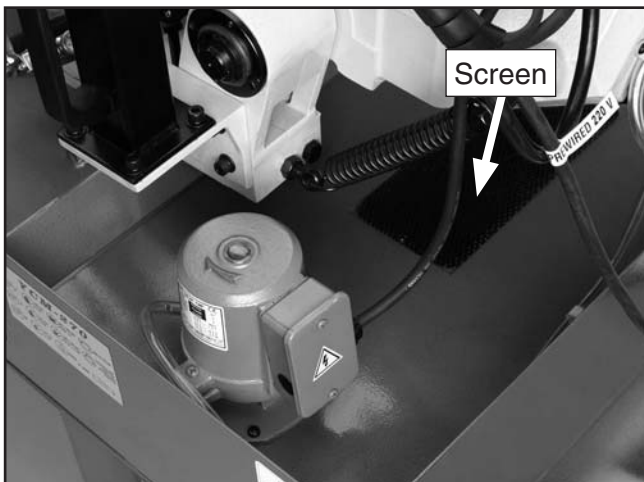

Figure 11. Cutting fluid system reservoir and cover.

4. Turn the cutting fluid pump switch **ON**, and adjust the valves on the cutting fluid hoses to control the flow of cutting fluid (see **Figure 12**).

Note: Too much flow at the fluid nozzle will make a mess and can make the work area unsafe; and not enough fluid at the cut will heat the blade, causing the blade teeth to load up and break.

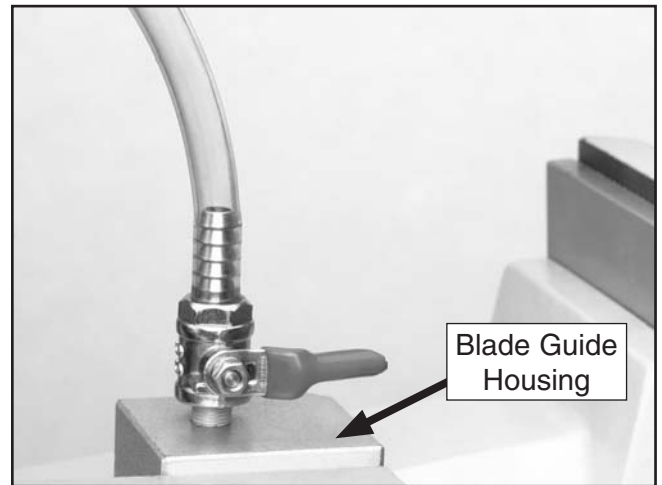

Figure 12. Cutting fluid control valve.

NOTICE

Keep the screen clear so cutting fluid can recycle to the pump reservoir. NEVER operate the pump with the reservoir below the low mark or you will over-heat the pump and void your warranty!

5. Monitor the cutting fluid level frequently to keep the system working properly.



Recommended Adjustments

The adjustments listed below have been performed at the factory. However, because of the many variables involved with shipping, we recommend that you verify the following adjustments before the **Test Run** and to ensure cutting results meet your standards.

Step-by-step instructions on verifying these adjustments can be found in **SECTION 7: SERVICE ADJUSTMENTS**.

Factory adjustments that should be verified:

1. Blade Tension (**Page 33**).
2. G0613 Blade Guide Adjustment (**Page 34**).
3. G0614 Blade Guide Adjustment (**Page 36**).
4. Stop Adjustments (**Page 38**).
5. Blade Squaring Adjustment (**Page 40**).

Test Run

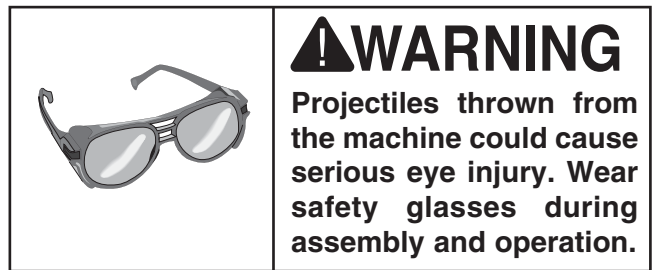

Starting the machine:

1. Read the entire instruction manual.
2. Make sure all tools and foreign objects have been removed from the machine.
3. Make sure that you verify the **Recommended Adjustments** listed on this page.
4. Fill the cutting fluid reservoir with cutting fluid if not done so already, DO NOT run the pump without cutting fluid or you will damage the pump.
5. Put on safety glasses and secure loose clothing or long hair.
6. Connect the bandsaw to power.
7. Raise the bandsaw and close the feed rate control knob to keep the saw in place.
8. Start the bandsaw while keeping your finger near the EMERGENCY STOP/OFF button at all times during the test run. The bandsaw should run smoothly with little or no vibration.

Note: *If the EMERGENCY STOP/OFF button is pressed, it needs to be twisted until it pops out or the bandsaw will not start.*

—If you hear or see any problems, immediately stop the bandsaw and correct before continuing.

—If you need any help with your bandsaw call our Tech Support at (570) 546-9663.



SECTION 4: OPERATIONS

Operation Safety

!WARNING

Damage to your eyes, lungs, and ears could result from using this machine without proper protective gear. Always wear safety glasses, a respirator, and hearing protection when operating this machine.

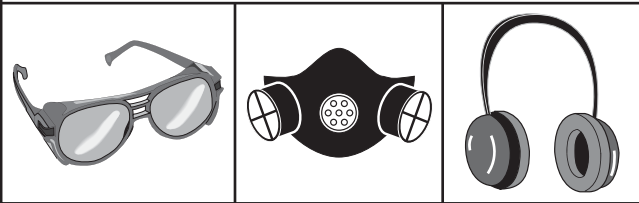

!WARNING

Loose hair and clothing could get caught in machinery and cause serious personal injury. Keep loose clothing and long hair away from moving machinery.

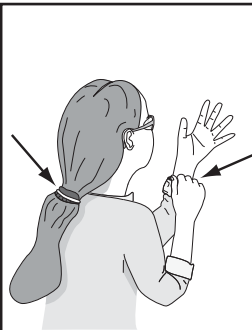

NOTICE

This bandsaw is for trained operators only. **WE STRONGLY RECOMMEND** that you read books, trade magazines, and get formal training before beginning any projects. Regardless of the content in this section, Grizzly Industrial will not be held liable for accidents caused by lack of training.

Cutting Angle

Your bandsaw has a locking turret with a range of 0° to 60° degrees.

To set the angle of cut:

1. Raise the bow to the highest position and lock in place (**Figure 12**).

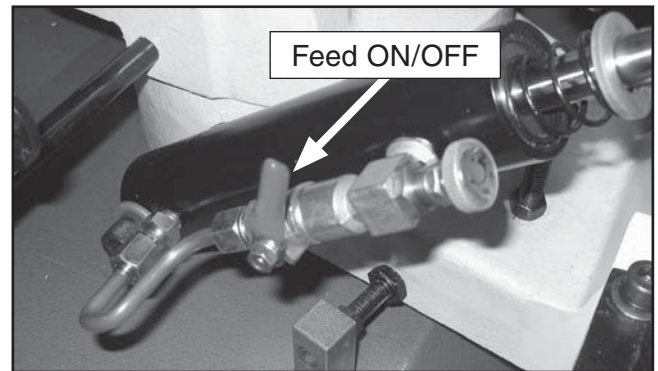

Figure 12. Feed ON/OFF Valve.

2. Move the swivel lock lever (**Figure 13**), to the left and rotate the headstock until the scale indicates the angle that you need.

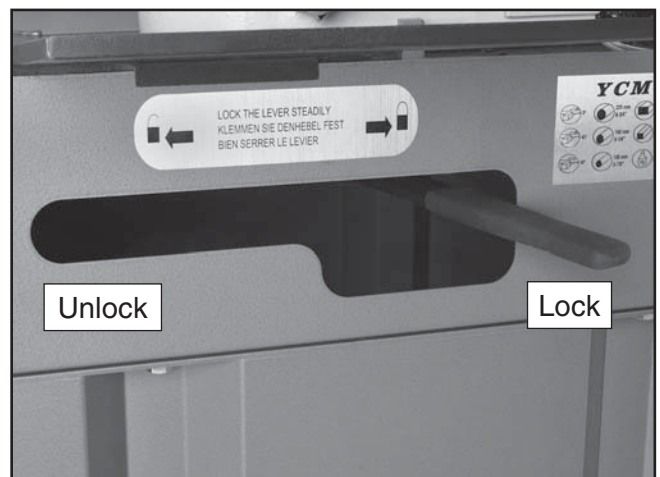

Figure 13. Swivel lock lever.

3. Move the swivel lock lever to the right to lock the headstock in place. The cutting angle is now set.



Workstop

Your bandsaw has an adjustable workstop (**Figure 14**) that is easy to install and to use.

To install the workstop:

1. Thread the workstop rod in the base and tighten the jam nut.
2. Slide the workstop onto the rod.

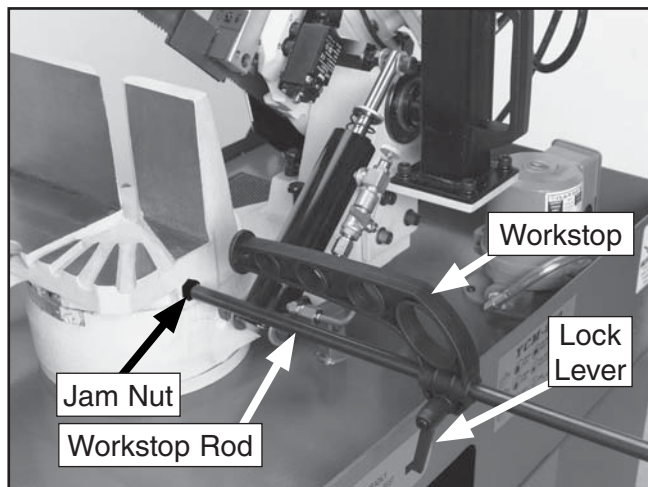

Figure 14. Workstop assembly.

3. Measure the distance from the blade to the workstop, slide workstop to the needed position and tighten the lock lever.

Vise

The vise has a quick tighten/release lever and, depending on the cut angle or workpiece shape, you can remove or install the aluminium vise clamp plate (**Figure 16**) for additional holding force.

To use the vise:

1. Raise the bow and lock it in place by closing the feed ON/OFF valve (**Figure 15**).

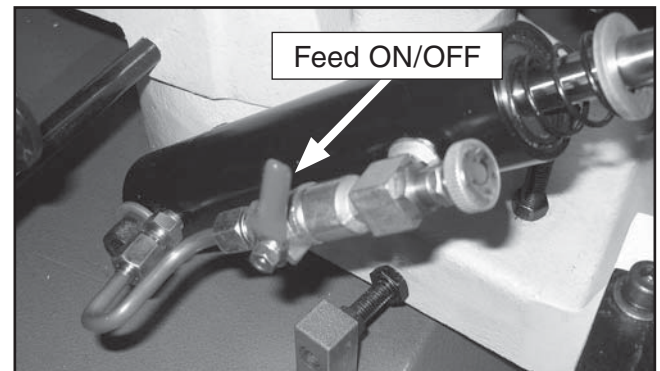

Figure 15. Feed ON/OFF Valve.

2. Insert the workpiece between the jaws.
3. Use the handwheel (**Figure 16**) to move the jaws so they are within 1/8" from clamping the workpiece.

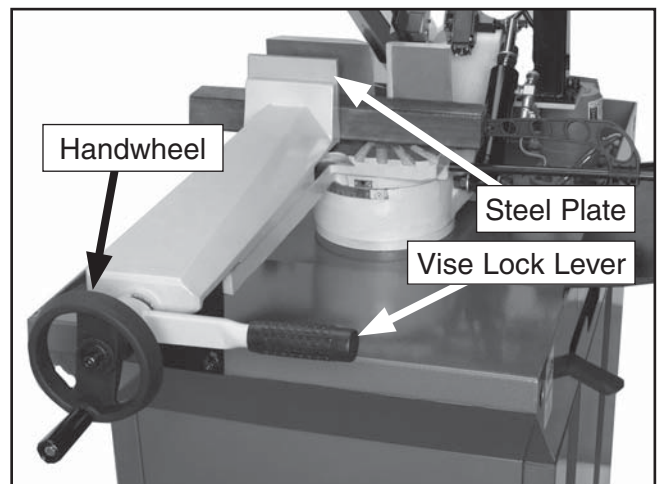

Figure 16. Vise options and controls.

4. Use the vise lock lever to hold the workpiece and quickly release the jaws to move the workpiece after a cut.



5. Use the chart shown in **Figure 17** as a guide to quickly position the workpiece between the vise jaws correctly and to avoid slipping during a cut. **DO NOT CUT STEEL THAT IS STACKED OR BUNDLED.** One or more workpieces will slip and damage the saw blade.

⚠ CAUTION
Always turn the saw *OFF* and allow the blade to come to a complete stop before using the vise! Failure to follow this caution may lead to injury.

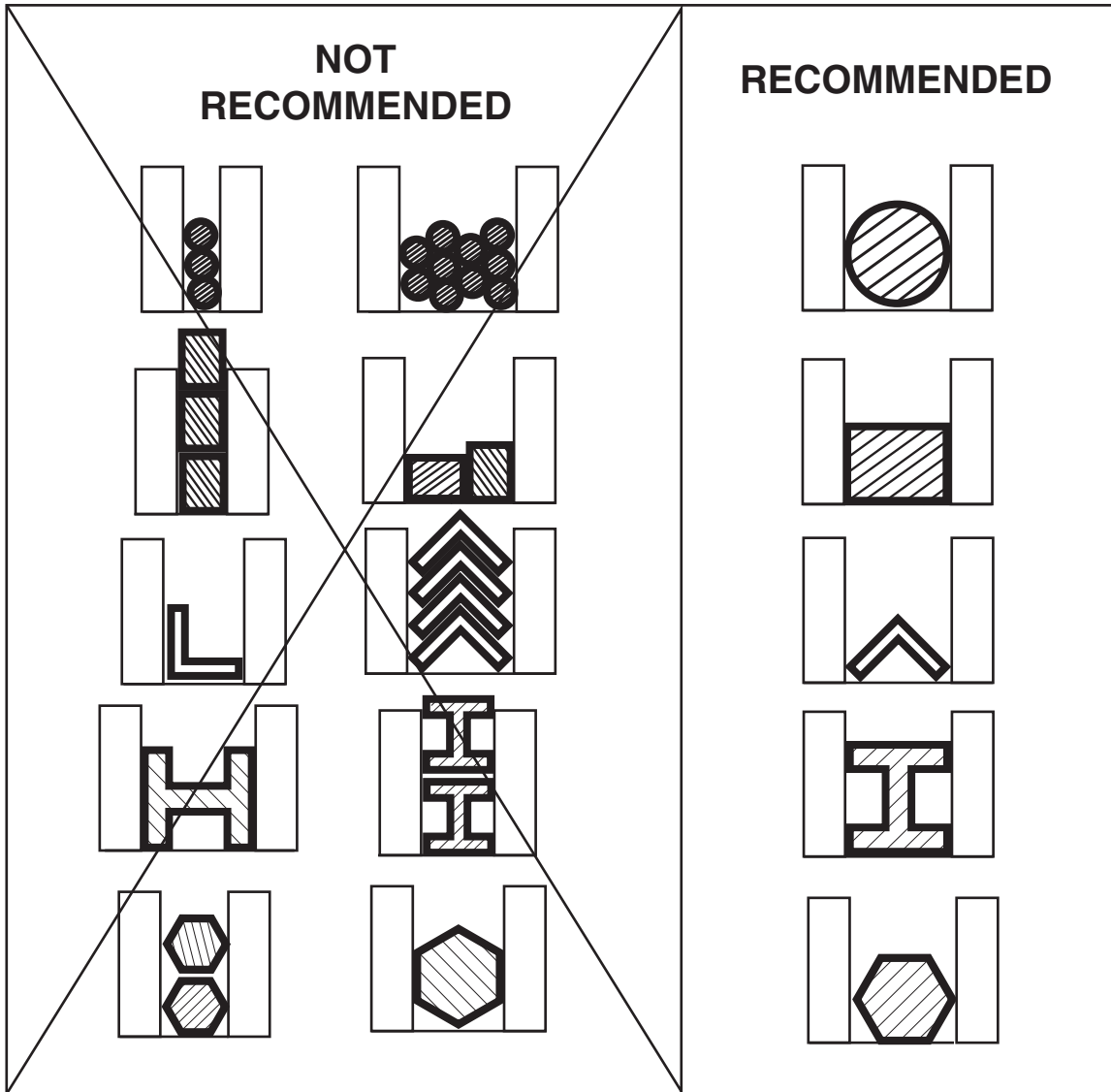

Figure 17. Vise clamping options.



Blade Selection

The Model G0613 uses a 3/4" wide x 82" long x 0.35" thick bandsaw blade.

The Model G0614 uses a 1" wide x 97 5/8" long x 0.35" thick bandsaw blade.

Do some research for your specific situation so you get the best blade to match your needs.

Selecting the right blade for the job depends on a variety of factors, such as the type of material being cut, hardness of the material, material shape, machine capability, and operator technique.

Grizzly offers a variety of selections that can be found in the current catalog and in **SECTION 5: ACCESSORIES** on **Page 27**.

The chart shown in **Figure 18** is a reproduction of the chart on the blade cover of your bandsaw. Use it as a rough guideline.

Blade Speed

The Model G0613 is a single speed (314 FPM) bandsaw. Like the G0614, it has a cutting fluid system which gives the saw a wider cutting range than a single speed bandsaw that is not equipped with a cutting fluid system.

The Model G0614 has a two speed control ranging from 170 to 341 feet per minute (FPM). The speed is controlled by a rotary switch and can be switched while the motor is operating.

NOTICE

On the Model G0614, DO NOT change motor speed during a cut as this may overload a series of engaged blade teeth.

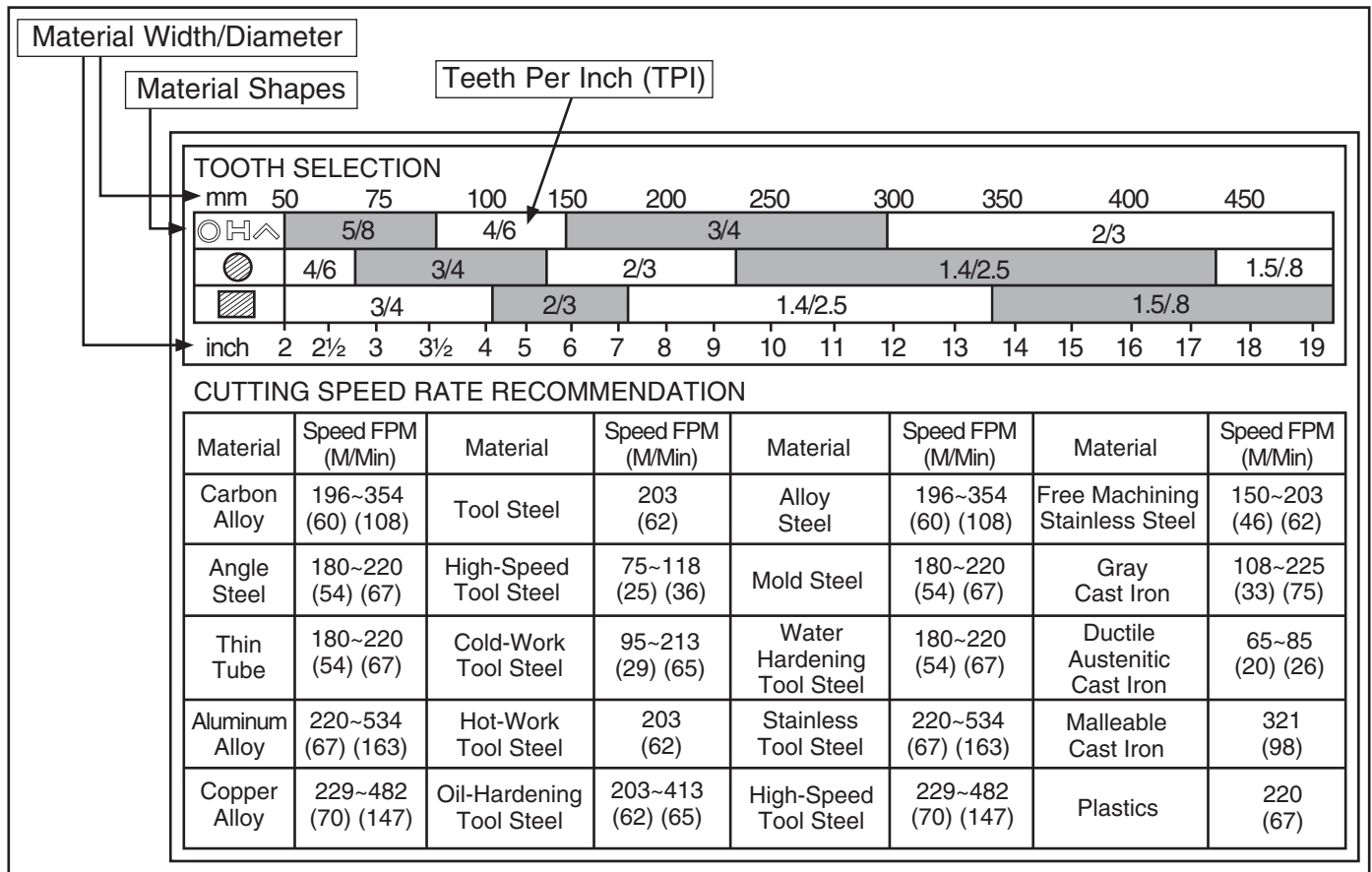

Figure 18. G0613/14 general blade selection and speed chart.



The table shown in **Figure 19** is a sampling of speed rates for various materials. Use these as a guideline, and use the cutting fluid system on your bandsaw to get the most life from your blades.

Material	Alloy ASTM Number	Blade Speed
Copper Alloys	173,932	Hi
	330,365	Hi
	623,624	Hi
	230,260,272	Lo
	280,264,632,655	Lo
	101,102,110,122,172	Lo
	1751,182,220,510	Lo
	625, 706, 715, 934	Lo
	630	Lo
	811	Lo
Carbon Steels	1117	Hi
	1137	Hi
	1141,1144	Hi
	1141 High Stress	Hi
	1030	Hi
	1008,1015,1020,1025	Hi
	1035	Hi
	1018,1021,1022	Hi
	1026,1513	Hi
	A36 (SHAPES),1040	Hi
	1042,1541	Lo
	1044,1045	Lo
	1060	Lo
1095	Lo	
Nickle	8615, 8620, 8622	Hi
Chrome	4340, E4340, 8630	Lo
Molybdenum	8640	Lo
Alloys	E9310	Lo
Tool Steels	A-6	Lo
	A-2	Lo
	A-10	Lo
	D-2	Lo
	H-11,H-12,H-13	Lo
Stainless Steels	420	Lo
	430	Lo
	410,502	Lo
	414	Lo
	431	Lo
	440C	Lo
	304, 324	Lo
	304L	Lo
	347	Lo
	316, 316L	Lo
	416	Lo

Figure 19. Material speed table.

Splash Tray

Use the splash tray to reduce cutting fluid lost at the end of a workpiece when cutting at 60°. The splash tray fits over the lip of the base as illustrated in **Figure 20**.



Figure 20. Splash tray installation.

Using Blade Guides

The upper blade guide should be as close to the workpiece as possible. This helps ensure straight cuts by keeping the blade from twisting or drifting off the cut line.

To adjust the upper blade guide:

Loosen the lever shown in **Figure 21** and slide the upper blade guide as close to the workpiece as possible, then tighten the knob.

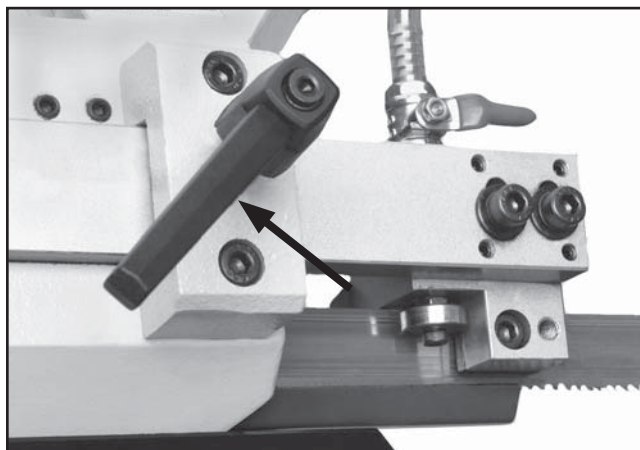

Figure 21. Blade guide lock lever.



Setting Feed Rate

Feed rate is the speed at which the bow and the saw blade cuts through a workpiece. The feed rate dial adjusts the feed rate. If a lubricant is used while cutting, the feed rate can be increased by approximately 15%. The feed ON/OFF lever starts and stops the lowering of the bow.

To set the feed rate:

1. Raise the bow to the highest position and lock it in place with the feed ON/OFF lever.
2. Set the feed rate dial to the desired feed rate; 1 is the slowest and 9 is the fastest.

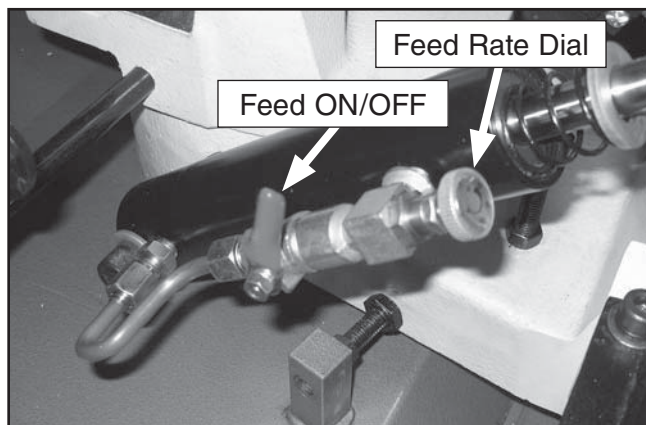
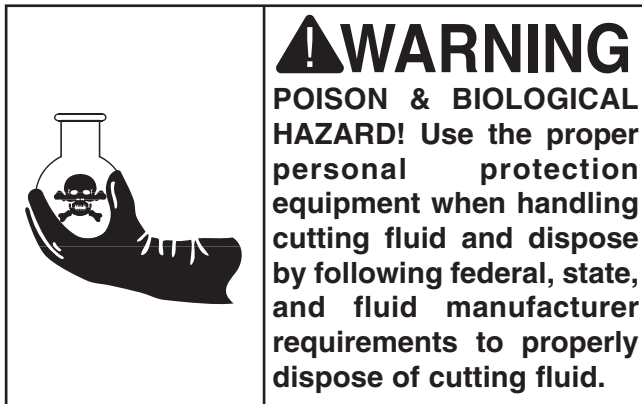

Figure 22. Feed rate dial.

3. Start the pump and the bandsaw and begin cutting.
 - If you get evenly-shaped chips that are slightly curled or spiraled with only a slight color change; the feed rate, blade speed, cutting fluid type, and blade type are correct.
 - If you get a tightly curled, warm shavings, brown to black in color, reduce the feed rate, increase blade speed or both.
 - If you get smoking blue-colored metal chips, slow the blade speed, use cutting fluid, reduce the feed rate, or a combination of the three.
 - If you get thin powder-like silver colored chips, increase feed rate, decrease the blade speed, or both.



Cutting Fluid Tips



While simple in concept and function, many issues must be taken into account to find and use the correct cutting fluid. For example, you must consider the workpiece type and hardness, its shape, the blade feed rate, blade TPI, the tooth type, and blade type, and cutting speed. Always follow all product warnings and contact the fluid manufacturer for unanswered questions.

Use the selections below to choose the appropriate cutting fluids:

- For cutting low alloy, low carbon, and general-purpose category metals with a bi-metal blade—use a water soluble cutting fluid.
- For cutting stainless steels, high carbon, and high alloy metals, brass, copper and mild steels—use "Neat Cutting Oil" (commonly undiluted mineral oils) that have extreme pressure additives (EP additives).
- For cutting cast iron, cutting fluid is not recommended.

Remember: Too much flow at the cutting fluid nozzle will make a mess and can make the work area unsafe; and not enough fluid at the cut will heat the blade, causing the blade teeth to load up and break.

Operation Tips

The following tips will help you safely and effectively operate your bandsaw and get the maximum life out of your saw blades.

NOTICE

Loosen blade tension at the end of each day to prolong blade life.

Tips for horizontal cutting:

- Use the work stop to quickly and accurately cut multiple pieces of stock to the same length.
- Clamp the material firmly in the vise jaws to ensure a straight cut through the material and use the positive lock to speed production.
- Let the blade reach full speed before engaging the workpiece.
- Never start a cut with the blade in contact with the workpiece and do not start a cut on a sharp edge.
- Chips should be curled and silvery. If the chips are thin and powder like, increase your feed rate.
- Burned chips indicate a need to reduce your blade speed.
- Wait until the blade has completely stopped before removing the workpiece from the vise, and avoid touching the cut end—it could be very hot!
- Support long pieces so they won't fall when cut, and flag the ends to alert passers-by of potential danger.
- Adjust the blade guides as close as possible to the workpiece to minimize side-to-side blade movement.
- Use cutting fluid when possible to increase blade life.



SECTION 5: ACCESSORIES

MODEL G0613

82" x 3/4" x 0.032"
Variable Pitch
Bi-Metal Blades:

H9726— 4-6 VP
H9727— 5-8 VP
H9728— 6-10 VP
H9729— 8-12 VP
H9730— 10-14 VP

MODEL G0614

97-5/8" x 1" x 0.032"
Variable Pitch
Bi-Metal Blades:

H9731— 4-6 VP
H9732— 5-8 VP
H9733— 6-10 VP
H9734— 8-12 VP
H9735— 10-14 VP



Figure 23. Blades

H5408—Blade Tensioning Gauge

The Blade Tensioning Gauge ensures long blade life, reduced blade breakage, and straight cutting by indicating correct tension. A precision dial indicator provides you with a direct readout in PSI.



Figure 24. H5408 Blade Tensioning Gauge.

H5405—Lenox® Lube Tube™

Lenox® Lube Tube™ is a stick lubricant designed to prevent heat buildup. Apply it directly to the blade to improve overall blade life and productivity. Can be used on ferrous and non-ferrous metals. Biodegradable, non-toxic, and non-staining 14.5 oz tube.



Figure 25. Lenox® Lube Tube™.

G7897—Machining Fluid

This biostable, soluble oil for heavy-duty machining applications provides stable pH performance, which resists bacteria, fungal growth, rancidity and odors. Can be used in light or heavy machining. Mix with water, 1:21 for general use or 1:11-1:16 for heavy use.



Figure 26. G7897 Machining Fluid.

Call 1-800-523-4777 To Order



G5618—Deburring Tool with Two Blades

G5619—Extra Aluminum Blades

G5620—Extra Brass and Cast Iron Blade

The quickest tool for smoothing freshly machined metal edges. Comes with two blades—one for steel/aluminum and one for brass/cast iron.



Figure 27. G5618 Deburring tool.

H1302—Standard Earmuffs

H4979—Deluxe Twin Cup Hearing Protector

H4977—Work-Tunes Radio Headset Earmuffs

Protect yourself comfortably with a pair of cushioned earmuffs. Especially important if you or employees operate for hours at a time.



Figure 29. Our most popular earmuffs.

G7984—Face Shield

H1298—Dust Sealed Safety Glasses

H1300—UV Blocking, Clear Safety Glasses

H2347—Uvex® Spitfire Safety Glasses

H0736—Shop Fox® Safety Glasses

Safety Glasses are essential to every shop. If you already have a pair, buy extras for visitors or employees. You can't be too careful when it comes to shop safety!

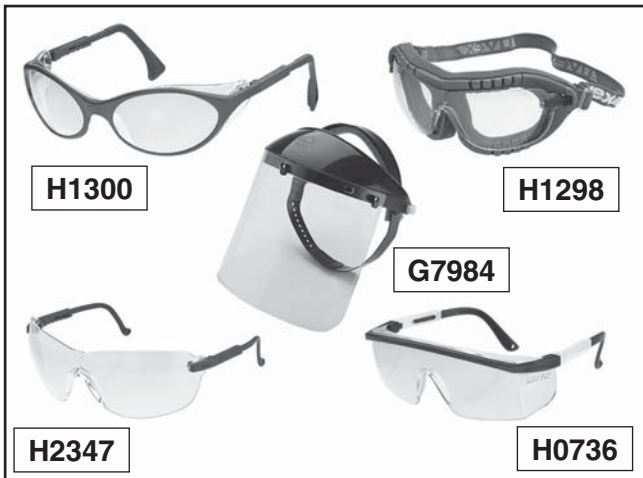

Figure 28. Our most popular safety glasses.

G9256—6" Dial Caliper

G9257—8" Dial Caliper

G9258—12" Dial Caliper

These traditional dial calipers are accurate to 0.001" and can measure outside surfaces, inside surfaces, and heights/depths. Features stainless steel, shock resistant construction and a dust proof display.

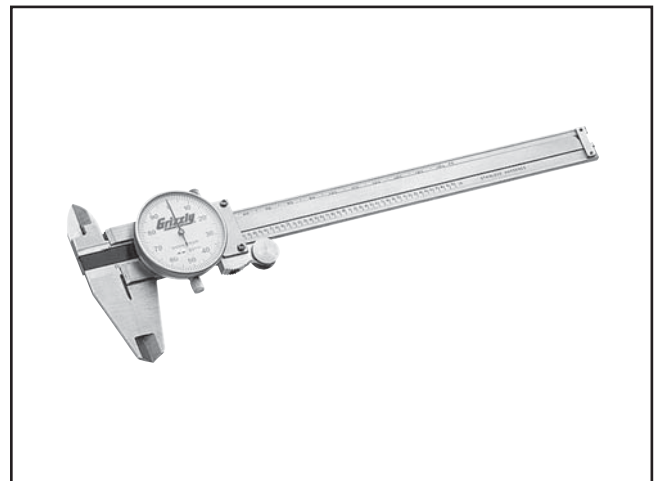
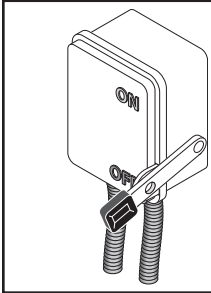

Figure 30. Grizzly® Dial Calipers.

Call 1-800-523-4777 To Order



SECTION 6: MAINTENANCE



⚠ WARNING
Always disconnect power to the machine before performing maintenance. Failure to do this may result in serious personal injury.

Schedule

For optimum performance from your machine, follow this maintenance schedule and refer to any specific instructions given in this section.

Daily Check:

- Loose mounting bolts.
- Damaged saw blade.
- Worn or damaged wires.
- Any other unsafe condition.
- Clean and wipe down after each use.
- Proper blade tension.
- Check cutting fluid level.

Monthly Check:

- Lubricate vise screw.
- Check cutting fluid level.

Annual Check:

- Replace cutting fluid and clean out tank. If the saw is used heavily, clean the tank and replace the cutting fluid at a sooner intervals.

Cleaning

Cleaning the Model G0613/14 is relatively easy. After using your bandsaw, vacuum up excess chips or by sweeping them up.

If using water based cutting fluid, wipe down and lubricate areas where the liquid may collect, causing rust after a period of time.

Lubrication

1. Before applying lubricant to any area, wipe the area clean to avoid contamination. Lubricate the blade tensioner leadscrew (**Figure 31**) with general purpose grease, and apply a coat of general purpose oil to all unprotected cast iron surfaces.

Note: All bearings and the gearbox on the Model G0613/14 are lubricated and sealed for life. No further attention is needed unless damage occurs.

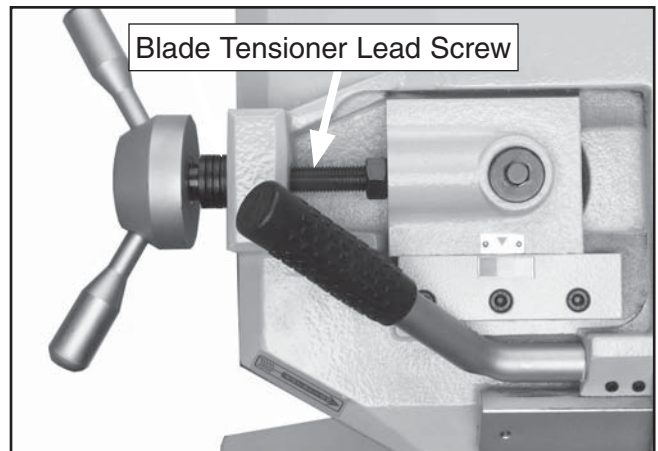

Figure 31. Lubrication points.

2. Lubricate the leadscrew as needed with general purpose grease. Apply a thin layer all along the leadscrew surface (see **Figure 32**).

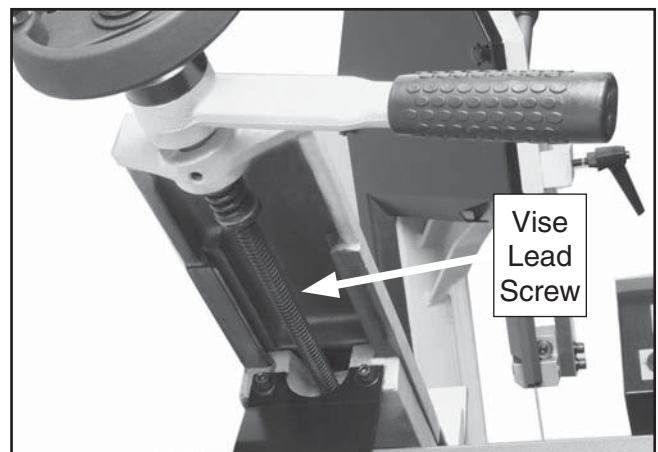

Figure 32. Vise leadscrew lubrication area.



SECTION 7: SERVICE

Review the troubleshooting and procedures in this section to fix your machine if a problem develops. If you need replacement parts or you are unsure of your repair skills, then feel free to call our Technical Support at (570) 546-9663.

Troubleshooting

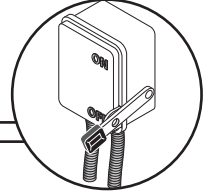

Motor & Electrical

SYMPTOM	POSSIBLE CAUSE	CORRECTIVE ACTION
Machine does not start or a breaker trips.	<ol style="list-style-type: none"> 1. E-Stop button pressed. 2. Plug/receptacle is at fault or wired incorrectly. 3. Start capacitor is at fault (G0613). 4. Wall fuse/circuit breaker is blown/tripped. 5. Motor connection wired incorrectly. 6. Power supply is at fault/switched OFF. 7. Motor ON/OFF switch is at fault. 8. Wiring is open/has high resistance. 9. Motor is at fault. 	<ol style="list-style-type: none"> 1. Twist E-Stop button until it pops out. 2. Test for good contacts; correct the wiring. 3. Test/replace capacitor if faulty. 4. Ensure correct size for machine load; replace weak breaker. 5. Correct motor wiring connections. 6. Ensure hot lines have correct voltage on all legs and main power supply is switched ON. 7. Replace faulty ON/OFF switch. 8. Check for broken wires or disconnected/corroded connections, and repair/replace as necessary. 9. Test/repair/replace.
Machine stalls or is under-powered.	<ol style="list-style-type: none"> 1. Wrong blade for the workpiece material. 2. Wrong workpiece material. 3. Feed rate/cutting speed too fast for task. 4. Blade is slipping on wheels. 5. Incorrect power supply voltage. 6. Motor bearings are at fault. 7. Plug/receptacle is at fault. 8. Motor connection is wired incorrectly. 9. Motor has overheated. 10. Motor is at fault. 	<ol style="list-style-type: none"> 1. Use blade with correct properties for your type of cutting. 2. Use metal with correct properties for your type of cutting. 3. Decrease feed rate/cutting speed. 4. Adjust blade guides and tension. 5. Ensure hot lines have correct voltage on all legs. 6. Test by rotating shaft; rotational grinding/loose shaft requires bearing replacement. 7. Test for good contacts; correct the wiring. 8. Correct motor wiring connections. 9. Clean off motor, let cool, and reduce workload. 10. Test/repair/replace.
Machine has vibration or noisy operation.	<ol style="list-style-type: none"> 1. Motor fan is rubbing on fan cover. 2. Blade is at fault. 3. Wormgear is at fault. 4. Wrong blade for material. 5. Speed is set too slow. 	<ol style="list-style-type: none"> 1. Replace dented fan cover; replace loose/damaged fan. 2. Replace/resharpen blade. 3. Rebuild gearbox for bad gear(s)/bearing(s). 4. Change blade. 5. Adjust speed as required.



Bandsaw Operations

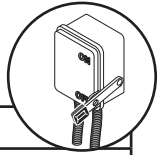

SYMPTOM	POSSIBLE CAUSE	CORRECTIVE ACTION
Machine is loud when cutting or bogs down in the cut.	<ol style="list-style-type: none"> Excessive feed rate. The blade TPI is too great, or the material is too coarse. 	<ol style="list-style-type: none"> Refer to Feed Rate on Page 25, or Blade Speed on Page 23 and adjust as required. Refer to Blade Selection on Page 23 and adjust as required.
Blades break often.	<ol style="list-style-type: none"> Blade is not tensioned correctly. The workpiece is loose in the vise. The feed or cut speed is wrong. The blade TPI is too great, or the material is too coarse. The blade is rubbing on the wheel flange. The bandsaw is being started with the blade resting on the workpiece. The guide bearings are misaligned, or the blade is rubbing on the wheel flange. The blade is too thick, or the blades are of low quality. 	<ol style="list-style-type: none"> Check to see that blade is not excessively tight or too loose. Clamp the workpiece tighter, or use a jig to hold the workpiece. Refer to Feed Rate on Page 25, or Blade Speed on Page 23, and adjust as required. Refer to Blade Selection on Page 23, and adjust as required. Refer to Blade Squaring on Page 40, and adjust as required. Start bandsaw and then slowly lower the headstock by setting the feed rate. Refer to Blade Squaring on Page 40, or Blade Guides on Page 34, and adjust as required. Use a higher quality blade.
Blade dulls prematurely.	<ol style="list-style-type: none"> The cutting speed is too fast. The blade TPI is too coarse. The blade feed pressure is too light. The workpiece has hard spots, welds, or scale. The blade is twisted. The blade is slipping on the wheels. 	<ol style="list-style-type: none"> Refer to Blade Speed on Page 23, and adjust as required. Refer to Blade Selection on Page 23, and adjust as required. Refer to Feed Rate on Page 25, and adjust as required. Increase the feed pressure, and reduce the cutting speed. Replace the blade. Refer to Blade Tension on Page 33, and adjust as required.
Blade wears on one side.	<ol style="list-style-type: none"> The blade guides are worn. The blade guide slide bracket is loose. The wheels are out of alignment. 	<ol style="list-style-type: none"> Refer to Blade Guides on Page 34 and replace or adjust. Tighten the blade guide bracket. Refer to Blade Squaring on Page 40, and adjust as required.
Teeth are ripping from the blade.	<ol style="list-style-type: none"> The feed pressure is too heavy and the blade speed is too slow; or the blade TPI is too coarse for the workpiece. The workpiece is vibrating in the vise. The blade gullets are loading up with chips. 	<ol style="list-style-type: none"> Refer to Blade Selection on Page 23 and decrease the feed pressure. Refer to Feed Rate on Page 25, and adjust as required. Re-clamp the workpiece in the vise, and use a jig if required. Use a coarser-tooth blade.
The cuts are crooked.	<ol style="list-style-type: none"> The feed pressure is too high. The guide bearings are out of adjustment, or too far away from the workpiece. The blade tension is low. The blade is dull. The blade speed is wrong. 	<ol style="list-style-type: none"> Refer to Feed Rate on Page 25, and adjust as required. Refer to Blade Guides on Page 34 and replace or adjust. Refer to Blade Tension on Page 33, and adjust as required. Refer to Blade Change on Page 32 and replace the blade. Refer to Blade Speed on Page 23, and adjust as required.



Blade Change

Change the blade when it becomes dull, damaged, or when you are using materials that require a blade of a certain type or tooth count.

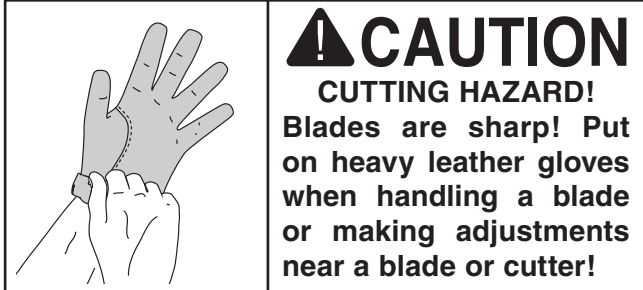

To change the blade on the bandsaw:

1. DISCONNECT THE BANDSAW FROM POWER!
2. Raise the bow of the bandsaw for access and close the feed control lever to hold the bow in place.

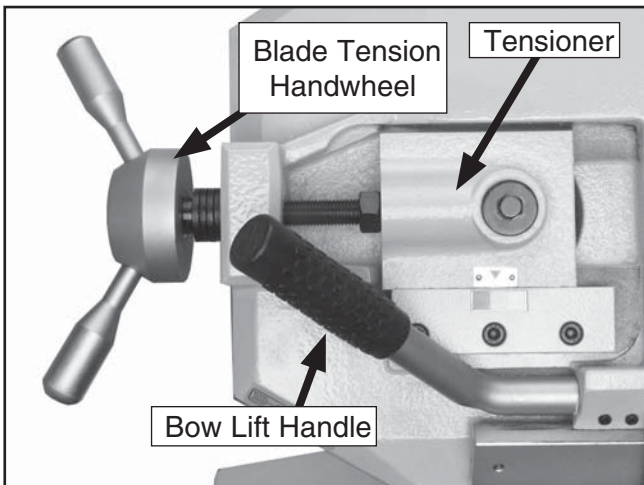

Figure 33. Blade tension handwheel and tensioner, and bow lift handle.

3. Slide the blade guides as far apart as possible, and remove the wheel access cover.
4. Remove both of the blade guide guards (**Figures 34 and 35**) from the bandsaw.

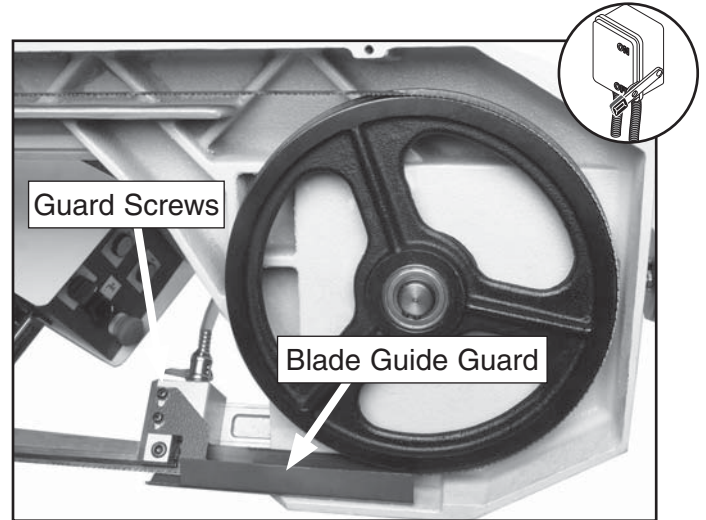



Figure 34. Installed blade and guide guard.

5. Loosen the blade tension handle in **Figure 33** and slip the blade off of the wheels.
6. Install the new blade through both blade guide bearings and around the bottom wheel.

 **Tip:** This is a good time to adjust the blade guides if you have not done so recently.

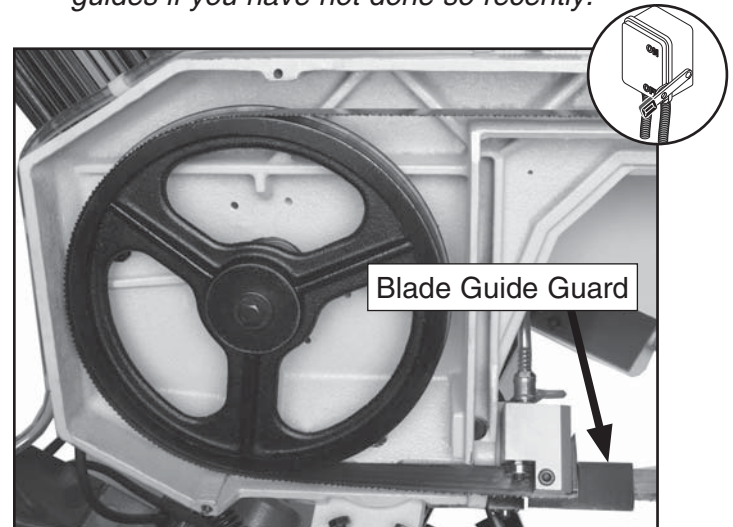



Figure 35. Installed blade and guide guard.

7. Hold the blade around the bottom wheel with one hand and slip it around the top wheel with the other hand, keeping the blade between the blade guide bearings.

 **Tip:** You can use a block of wood to tap on the blade in order to fully seat the blade.

Note: Do not flip the blade inside out so the blade will be installed in the wrong direction. Make sure the blade teeth are facing toward the workpiece and the direction of cut.



8. When the blade is around both wheels, adjust the position so the back of the blade is against the shoulder of the wheels.
9. Reinstall the blade cover and the blade guide guards.
10. Now go to the **Blade Tension** procedure and set the blade tension.

2. Using the graduated scale on the blade tension indicator (**Figure 37**) turn the blade tension handwheel so the tension is in the orange range when using the saw. When the saw is not being used, adjust the tension to the yellow range.

Note: For carbon blades, the blade tension should be 20,000 PSI. For bi-metal blades, like the one supplied with your machine, the blade should be tensioned from 20,000 to 22,000 PSI.

Blade Tension

Proper blade tension is essential to long blade life, straight cuts, and efficient cutting. The Model G0613/14 features a blade tension indicator to assist you with blade tensioning.

Two major signs that you do not have proper blade tension are: 1) The blade stalls in the cut and slips on the wheels, and 2) the blade frequently breaks from being too tight.

NOTICE

Loosen blade tension at the end of each day to prolong blade life.

To tension the blade on the bandsaw:

1. Locate the blade tension handle (**Figure 36**) and add a few drops of oil on the lead screw.

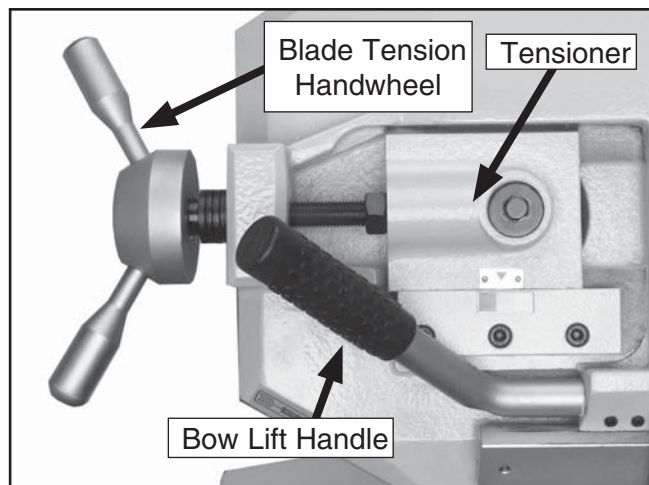

Figure 36. Blade tension handwheel, tensioner, bow lift handle.

If you are using a blade tensioning gauge, like the one found in **SECTION 5: ACCESSORIES** on **Page 27**, you will find the specifications below useful. Follow the manual instructions included with your gauge and the blade manufacturer's recommendations on blade tension.

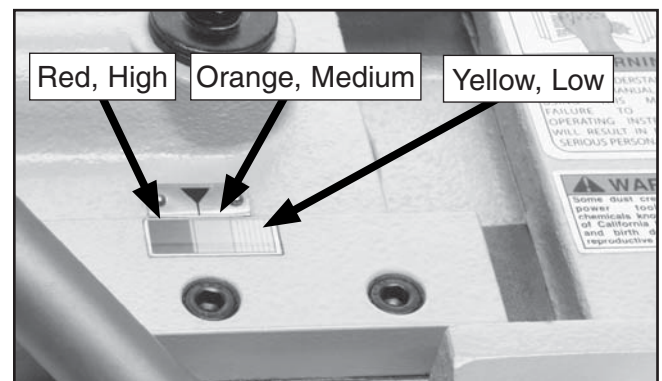

Figure 37. Blade tension scale.

3. When the correct tension is reached, adjust the tension stop bolt so when you need to de-tension and re-tension the blade, the handwheel will stop at your predetermined tension setting. (**Figure 38**).

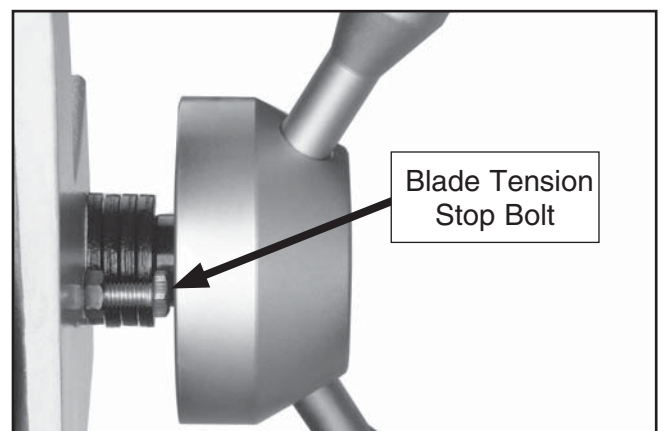
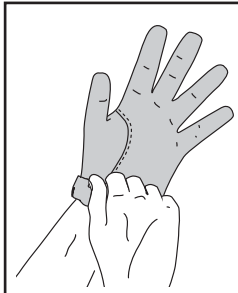

Figure 38. Blade tension stop bolt.



Blade Guides (G0613)

The blade guides have a basic factory adjustment, but due to shipping and storage we recommend that you readjust the blade guides yourself to ensure the cuts will be your standards.



CAUTION
CUTTING HAZARD!
Blades are sharp! Put on heavy leather gloves when handling a blade or making adjustments near a blade or cutter!

To adjust the blade guides:

1. Make sure the blade is oiled, tensioned, and tracking correctly.
2. DISCONNECT THE BANDSAW FROM POWER!
3. Raise and lock the bow in place and slide the guides together as close as you can and lock into place.
4. Loosen the two cap screws and the blade guide guard shown in **Figure 39**.

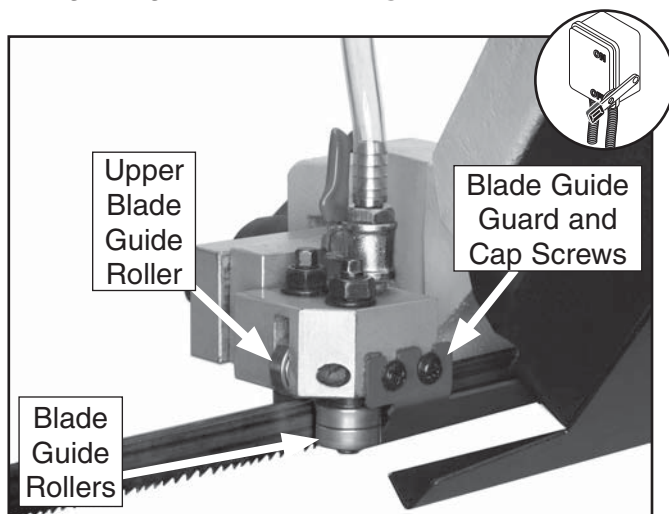

Figure 39. Upper blade guide components.

5. Loosen the cap screws (**Figure 41**), and adjust the blade guide housing so the back of the blade slightly touches the bearing and the guide housing is not tilted.

6. Tighten the cap screws.

Note: To access the cap screws on the other blade guide, you will have to remove the two Phillips head screws (**Figure 40**) and move the limit switch and its bracket out of the way.

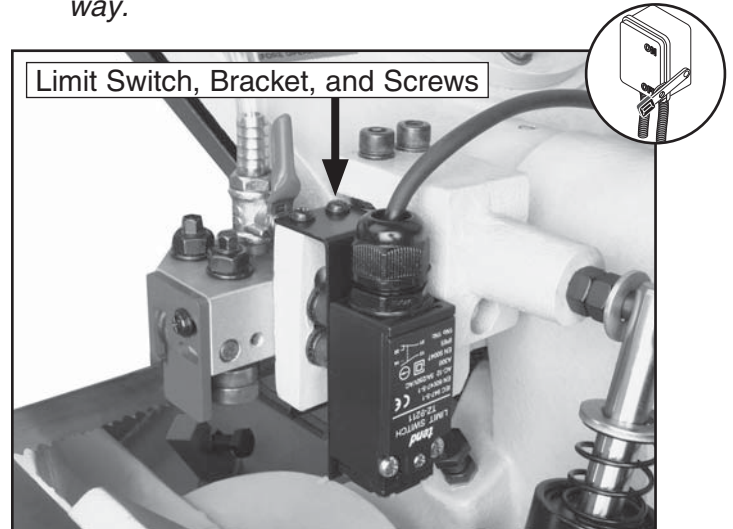

Figure 40. Lower blade guide limit switch.

7. Loosen the 14mm jam nuts and rotate the 7mm hex on top of the bearing eccentrics (**Figure 41**), and adjust the bearings against the side of the blade.

Tip: There should be no gap between the blade and the bearings. To set this clearance to zero without fighting the twist of the blade, remove the blade guide assemblies, set this clearance to the blade thickness, then reinstall the blade guide assemblies.

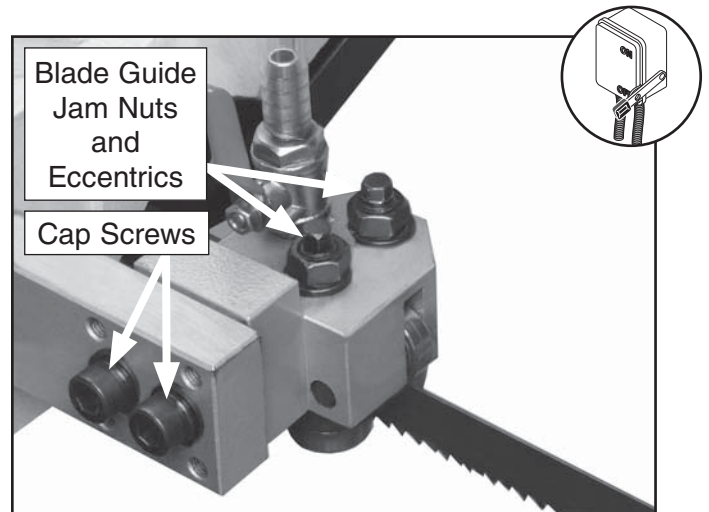

Figure 41. Blade guide adjustment locations.



8. Double check bearing adjustments.
9. Adjust the other blade guide, and reinstall the blade guide guards and the limit switch.
10. Adjust the auto stop bolt and the bow stop bolt (**Figure 42**), so the bandsaw motor will stop when the blade teeth are just below the vise table surface.
11. Go to **Setting Stops** on **Page 38** and complete the steps to make sure the cuts will be perpendicular to the table.

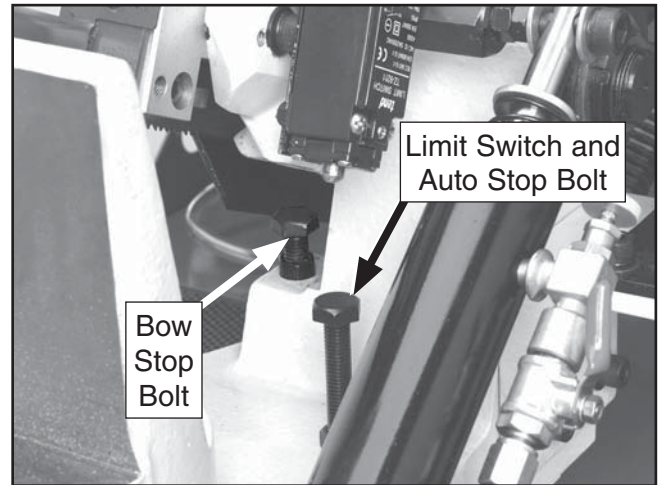
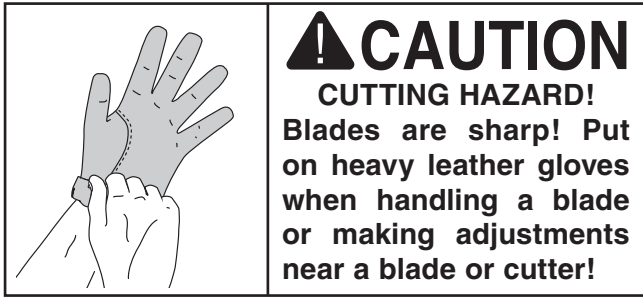

Figure 42. Auto stop and bow stop bolts.



Blade Guides (G0614)

The blade guides have a basic factory adjustment, but due to shipping and storage we recommend that you readjust the blade guides yourself to ensure the cuts will be your standards.



To adjust the blade guides:

1. Make sure the blade is oiled, tensioned, and tracking correctly.
2. DISCONNECT THE BANDSAW FROM POWER!
3. Raise and lock the bow in place and slide the guides together as close as you can and lock into place.
4. Remove the two Phillips head screws and the blade guide guard, (see **Figure 43**).

Tip: *There should be no gap between the blade and the bearings or the carbide blade guides. To set the clearance without fighting blade twist, remove the blade guides, and set this clearance to the blade thickness and then reinstall the blade guides.*

5. Make sure the guide housing has not tilted.

6. Loosen both of the cap screws (**Figure 43**) and push the guide bearing housing down until the upper carbide pad rests on the back of the saw blade.

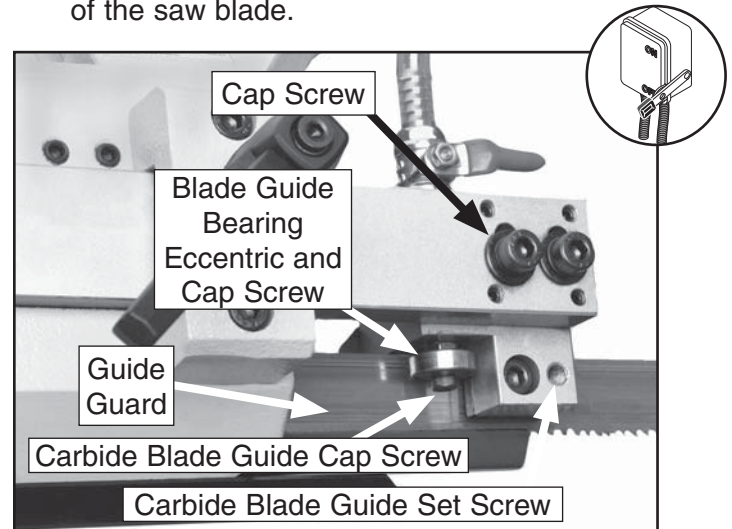

Figure 43. Upper blade guide adjustments.

Note: *To access the cap screws on the other blade guide, you must remove the two Phillips head screws (**Figure 44**), and move the limit switch and its bracket out of the way.*

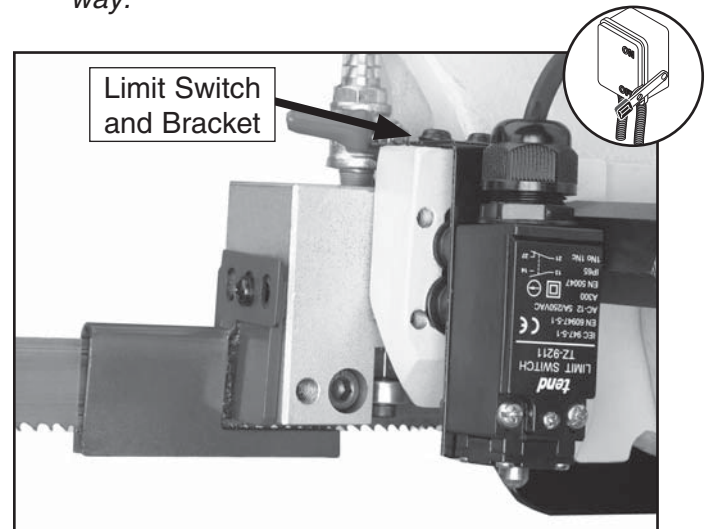

Figure 44. Lower blade guide limit switch.



- Loosen the cap screw, rotate the 10mm hex eccentric (**Figure 45**), and adjust the bearing against the side of the blade so there is no clearance, but the bearing is not overloaded.

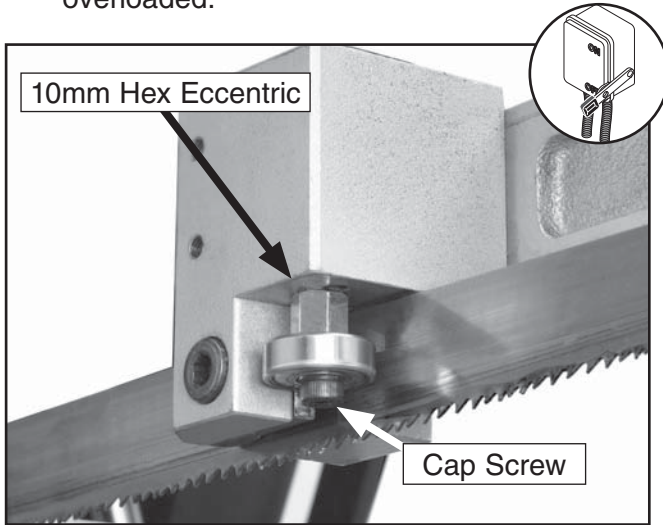

Figure 45. Upper blade guide adjustments.

- Double check bearing adjustments.
- Adjust the other blade guide.
- Loosen the carbide guide cap screw and use the set screw (**Figure 43**) to set the carbide guide clearance to zero, but do not tighten the set screw so the carbide guides pinch the blade.
- Tighten the cap screw making sure that when you tighten it, the carbide guide does not rotate out of the guide housing.
- Adjust the other set of carbide guides.

- When finished with the carbide guide adjustments, make sure the ball bearing guide (**Figure 46**) adjustments have not changed. Re-adjust if required.

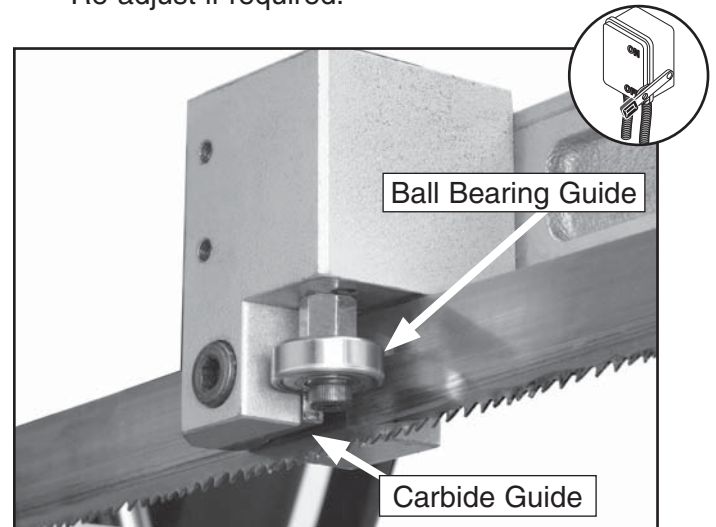

Figure 46. Guide types.

- Reinstall the guide guards and the limit switch and bracket.
- Adjust the auto stop bolt and the bow stop bolt (**Figure 47**), so the bandsaw motor will stop when the blade teeth are just below the vise table surface.

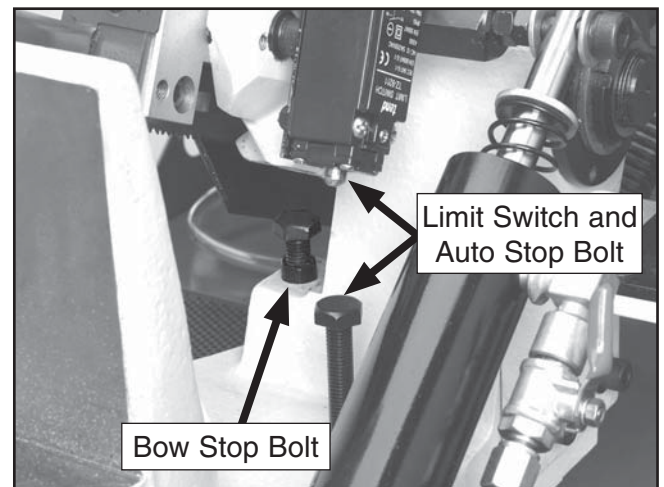

Figure 47. Auto stop.

- Go to **Swivel Stops** on **Page 38** and complete the steps to make sure the cuts will be perpendicular to the table.



Swivel Stops

The blade swivel stops are factory set. However, due to shipping and storage we recommend that you check the 0° degree and the 60° degree stops yourself to ensure the cuts will be your standards. **Note:** *The accuracy range for the scale is approximately 1/2° degree.*

To adjust the blade-to-vice squareness:

1. Make sure the blade is oiled, tensioned, and tracking correctly, and that the guides are set.
2. **DISCONNECT THE BANDSAW FROM POWER!**
3. Raise the bow, move and lock the headstock to zero (**Figure 48**), then lower the bow.

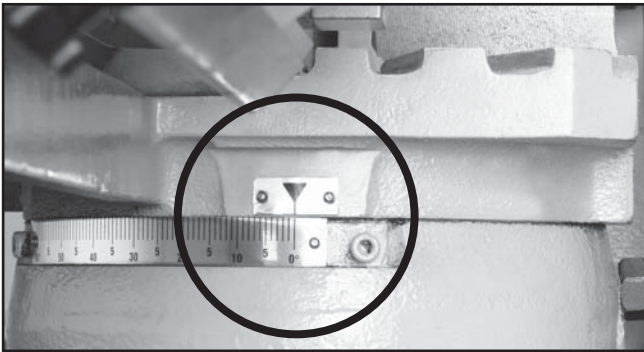

Figure 48. Bow and headstock moved to zero.

4. Observe the scale, and if the headstock has not completely stopped at zero, or if it has overshot the zero mark, adjust the zero stop (**Figure 49**) so it will line up with the mark .

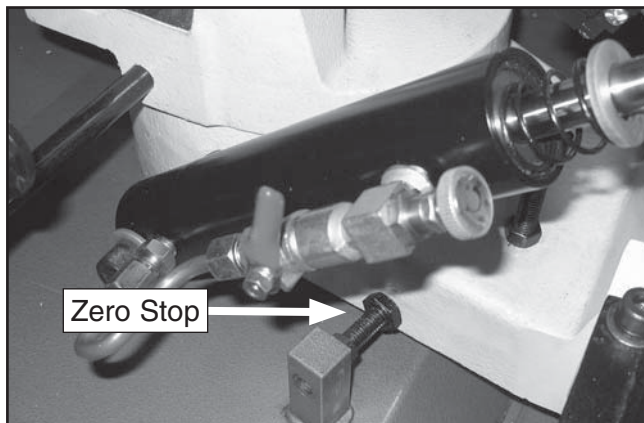

Figure 49. Zero degree swivel stop.

5. Raise the bow, move and lock the headstock to 60° , then lower the bow.
6. Read the scale. The bandsaw blade should be at 60°.

—If the headstock did not completely reach 60°, or it has overshot the mark, adjust the stop (**Figure 50**) so it will line up with the 60° mark.

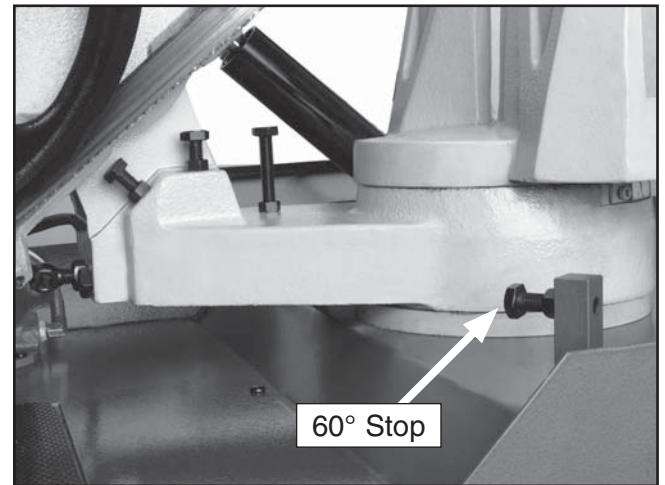

Figure 50. 60° swivel stop.

7. Go to **Blade Squaring** on **Page 40** and complete the steps to make sure the cuts will be perpendicular to the table.



Feed Stop

It may be necessary to adjust the feed stop before you make blade adjustments. The blade should never rest on or rub on any part of the vise assembly. Also, the over-tilt stop may be adjusted to stop the bow from being lifted past 40°, causing machine instability and hydraulic cylinder damage.

To adjust the feed stop bolt:

Adjust the feed stop bolt and jam nut (**Figure 51**), so the bandsaw blade teeth are just below the vise table surface when the cut is complete.

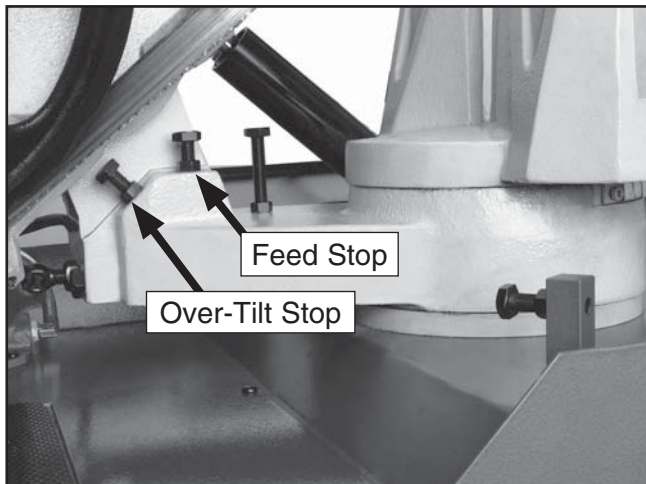

Figure 51. Feed stop bolt.

Feed Auto Stop

It may be necessary to adjust the auto stop after you have removed the limit switch for adjustment or maintenance.

To set the auto stop:

Adjust the auto stop bolt and jam nut (**Figure 52**), so the bandsaw blade teeth are just below the vise table surface when the saw blade has completed its cut.

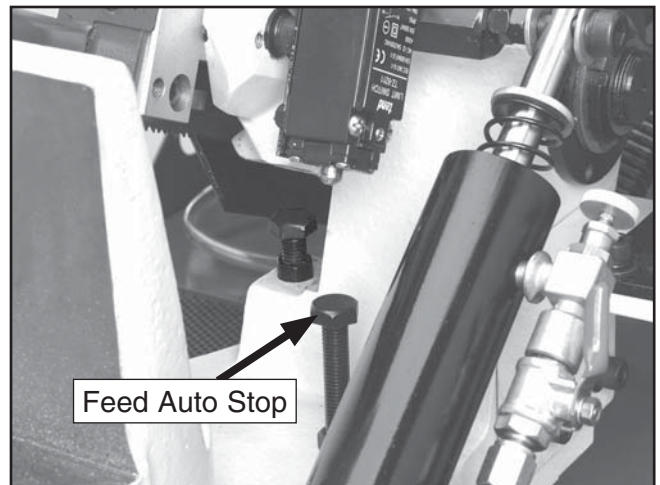

Figure 52. Feed auto stop.



Blade-to-Vise Squareness

The blade-to-vise squareness is factory set. However, due to shipping and storage we recommend that you check the blade alignment yourself to ensure the cuts will be your standards.

To adjust the blade-to-vise squareness:

1. DISCONNECT THE BANDSAW FROM POWER!
2. Make sure the blade is oiled, tensioned, and tracking correctly, and that the guides and stops are set.
3. Raise the bow, move the headstock to zero (**Figure 53**) and lower the bow.

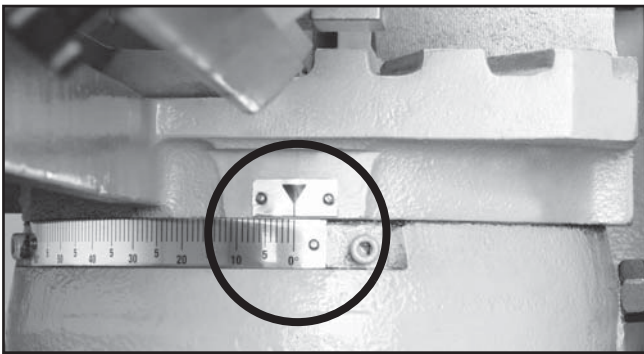

Figure 53. Bow and headstock moved to zero.

4. Place a quality square against the vise and the side of the blade (**Figure 54**) to verify the blade is square with the vise.

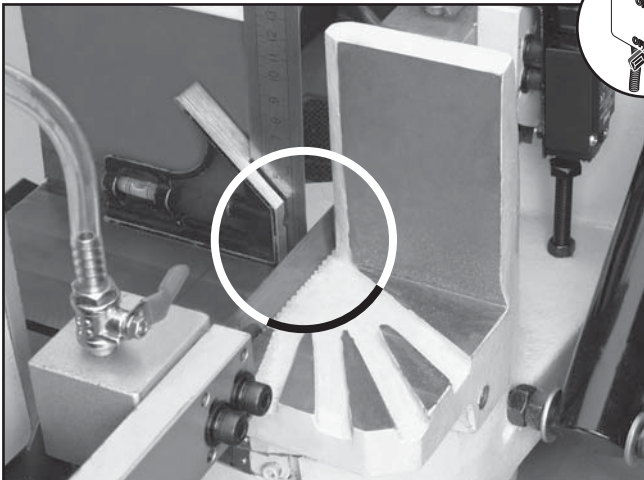

Figure 54. Checking blade squareness to vise.

—If blade is tilted and not perpendicular to the vise surface as indicated by the square, adjust the blade guide housing so it tilts the blade square with the vise.

Note: On the G0613 only one blade guide can be tilted, and on the G0614 both will need to be tilted.

5. Slide both blade guards as far as you can apart and lock into place.

Note: On the G0614, to access the cap screws on the other blade guide, remove the two Phillips head screws securing it, then move the limit switch and its bracket out of the way.

6. Loosen the two cap screws, then alternately adjust the four 4mm set screws to tilt the blade guide assembly and the blade square the vise. See **Figure 55** or **56** for your model of bandsaw.

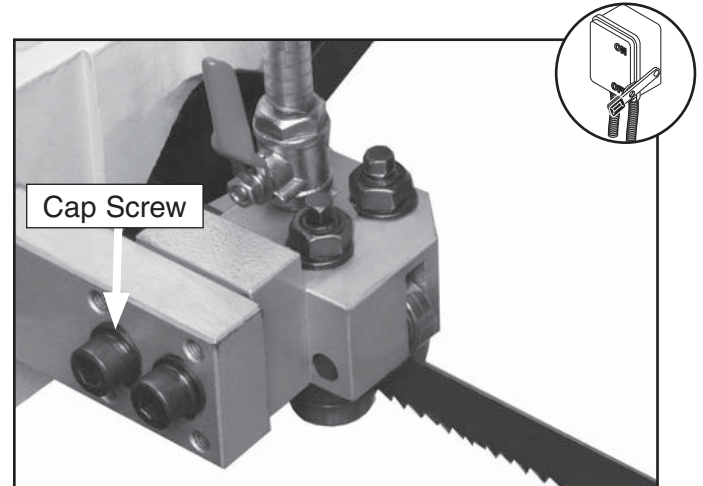

Figure 55. G0613 blade guide adjustment.

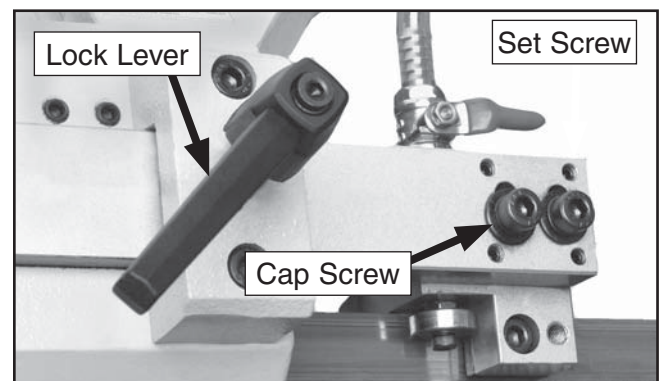

Figure 56. G0614 blade guide adjustment.

7. Snug the 6mm cap screws in place to hold the new blade and guide setting.



Electrical Components (G0613)

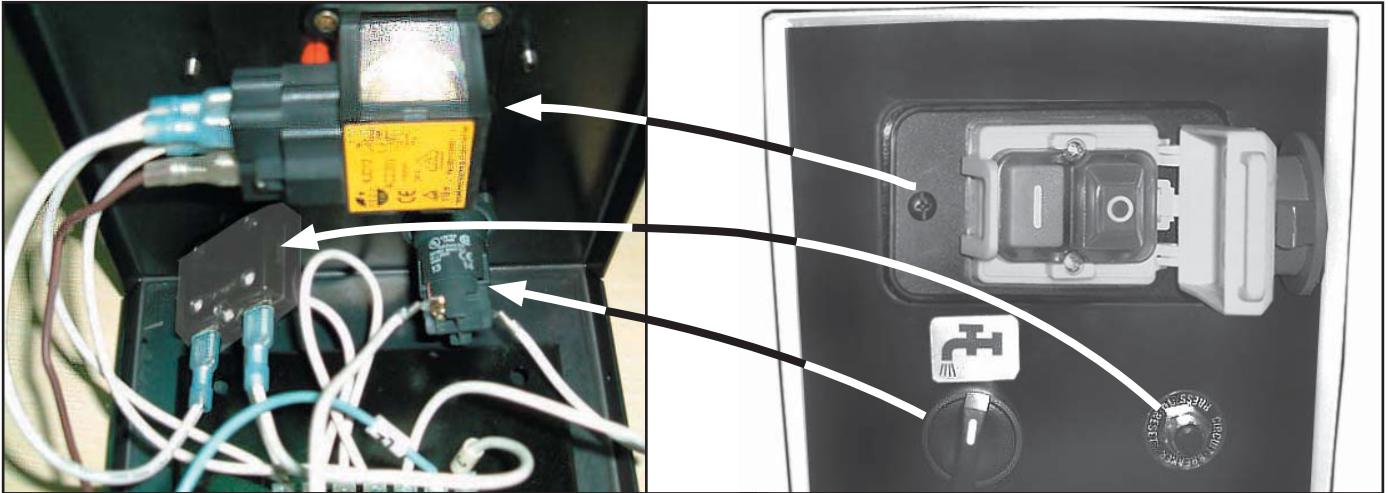

Figure 57. G0613 control panel wiring.

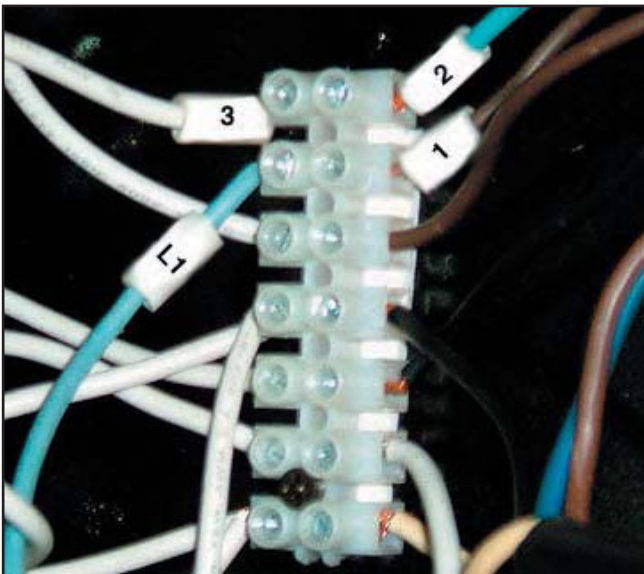

Figure 58. G0613 main electrical box junction.

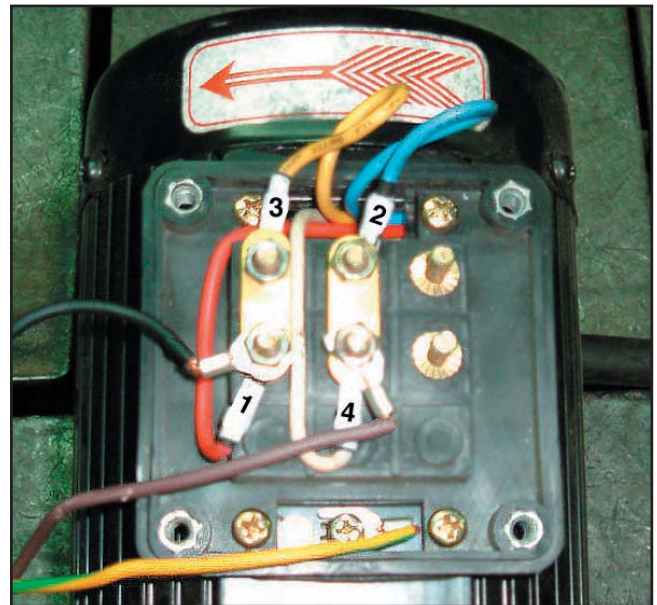

Figure 60. G0613 pump motor junction box.

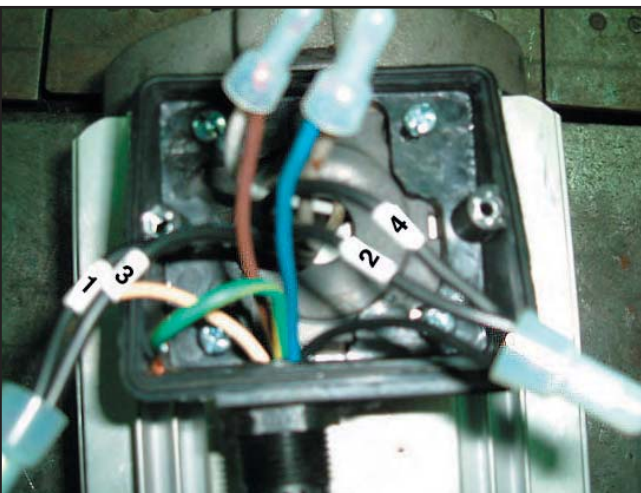

Figure 59. G0613 saw motor junction box.



Figure 61. G0613 blade stop limit switch.



Electrical Components (G0614)



Figure 62. G0614 ON button.

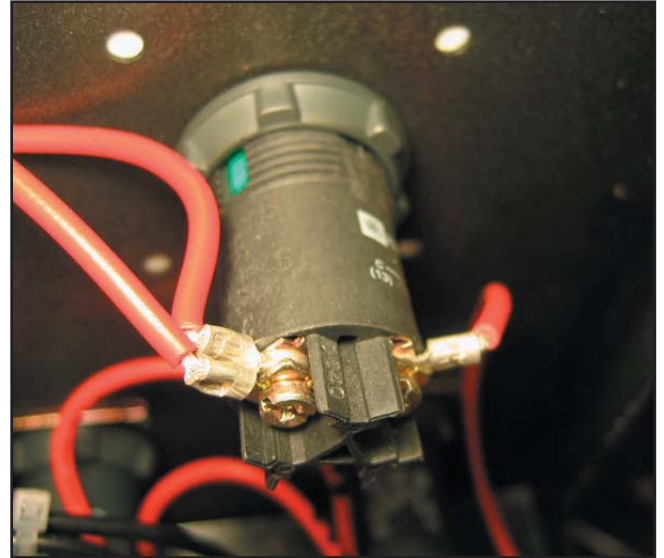

Figure 64. G0614 OFF button.

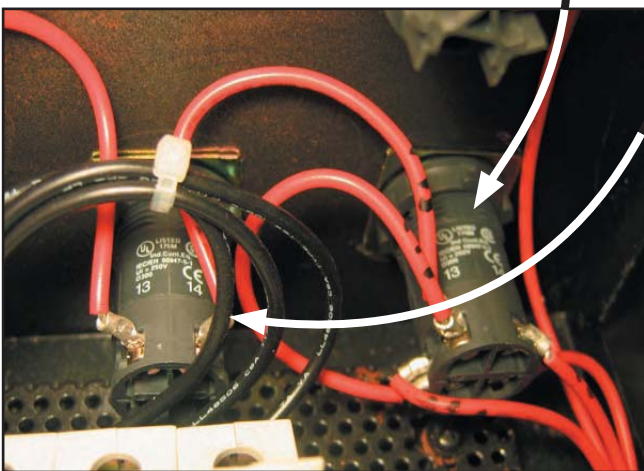
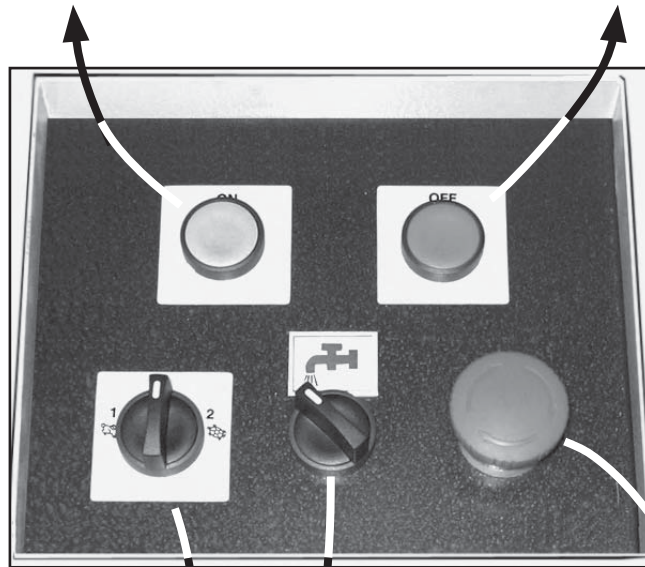

Figure 63. G0614 Pump and speed switches.

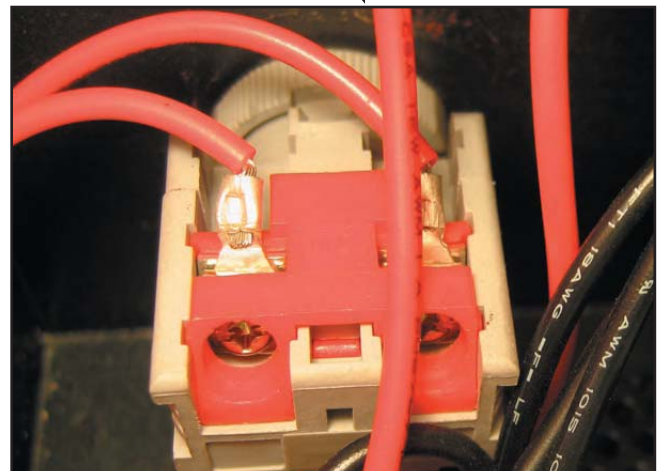

Figure 65. G0614 Emergency stop button.



Electrical Components (G0614)

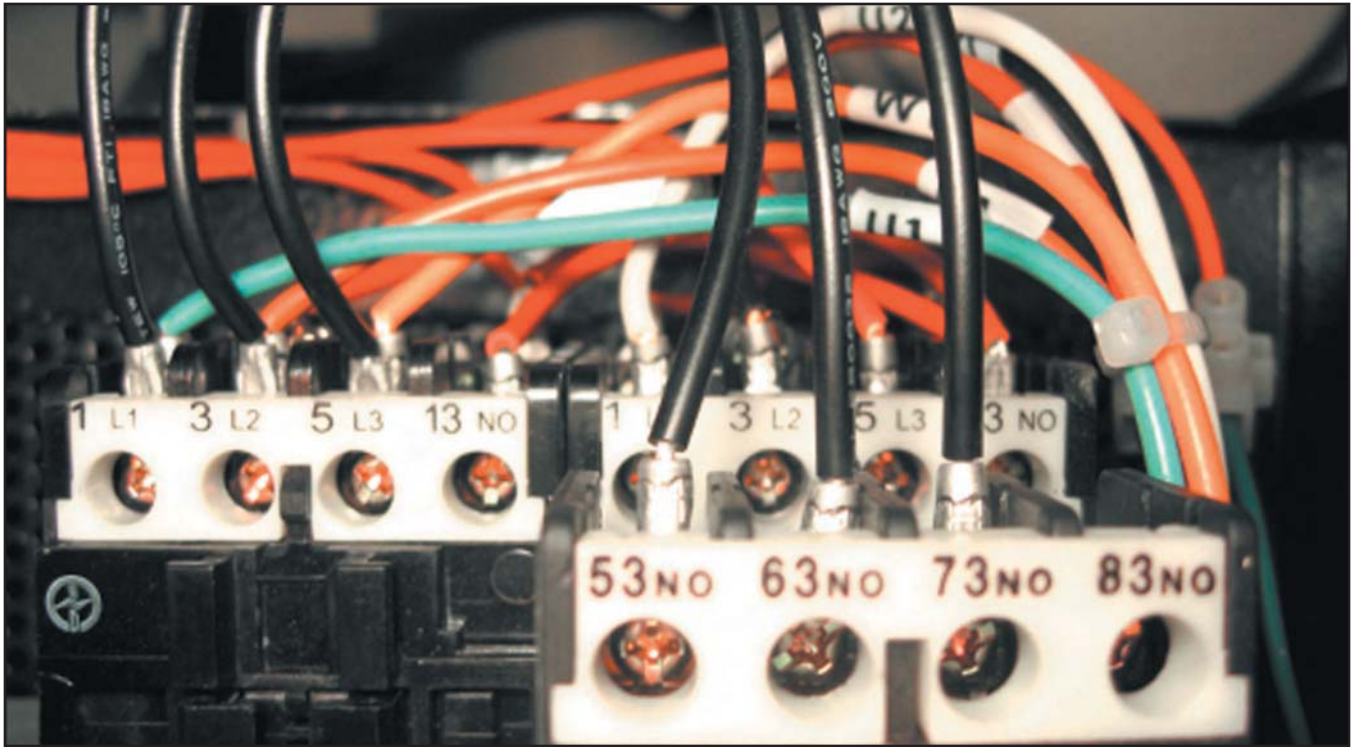

Figure 66. G0614 contactors.

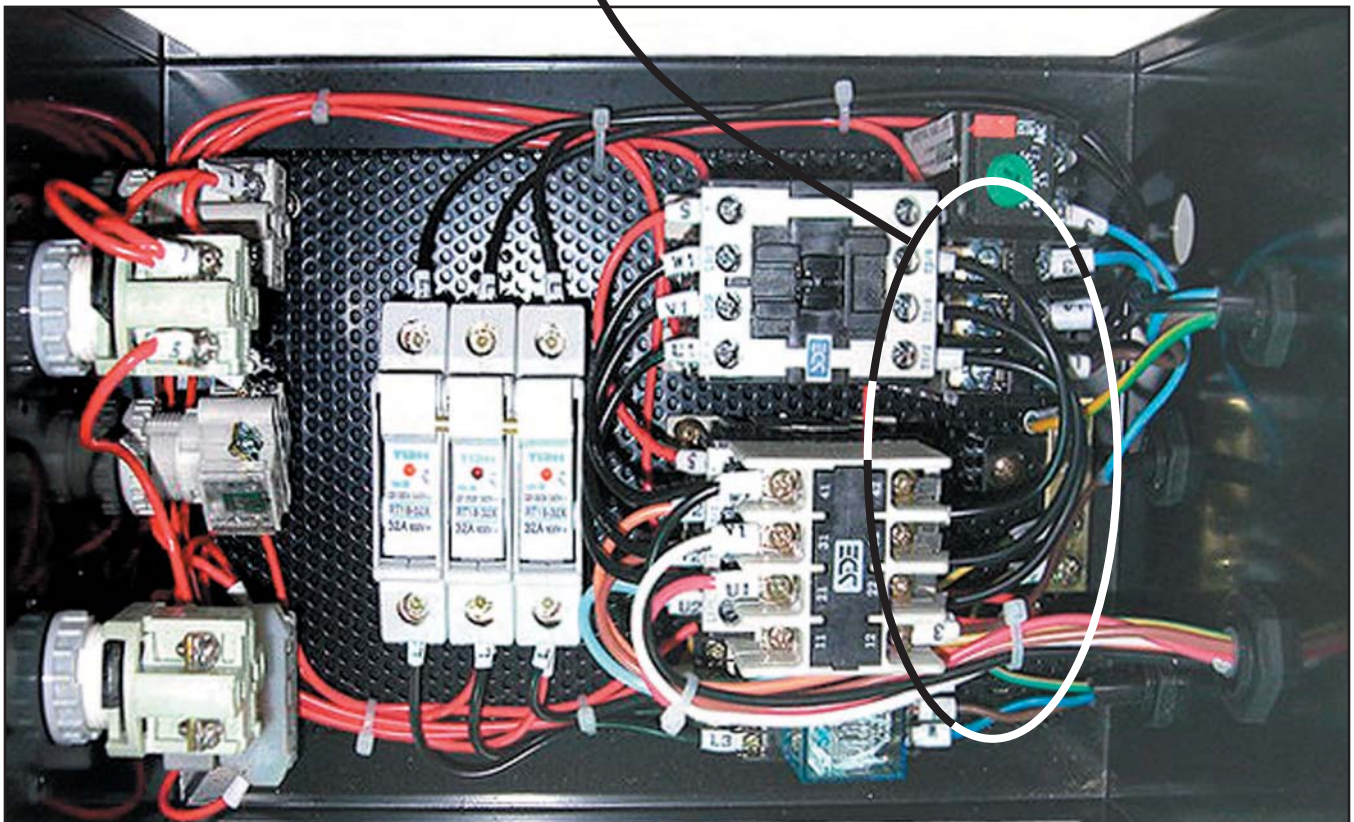

Figure 67. G0614 control box.



Electrical Components (G0614)

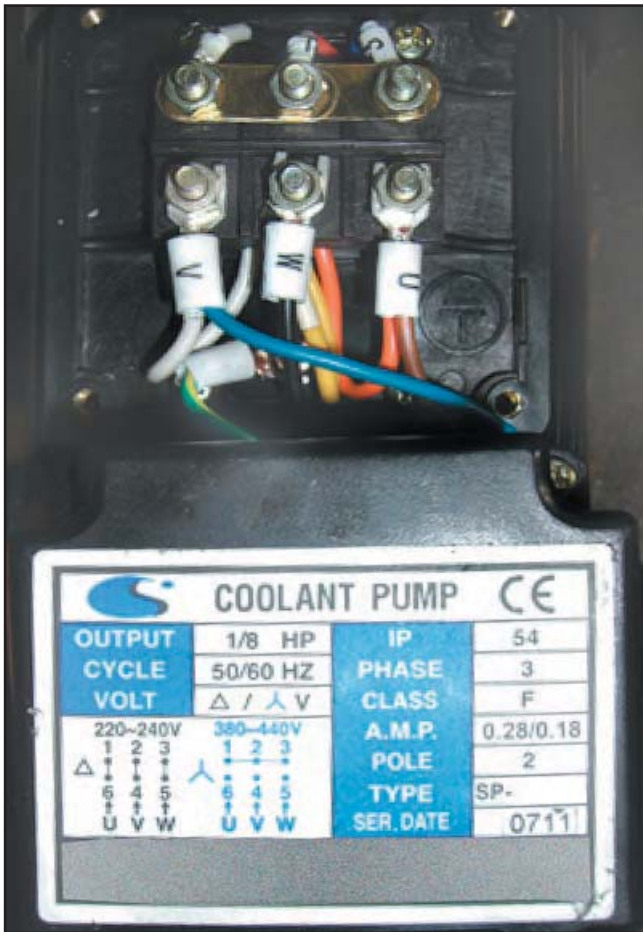

Figure 68. G0614 pump motor data/connection.

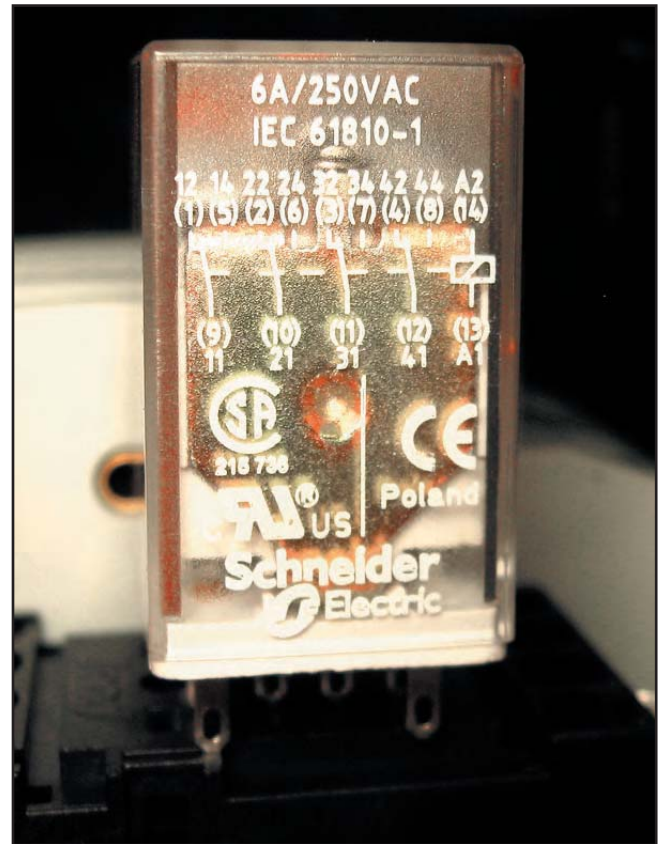

Figure 69. G0614 pump relay.

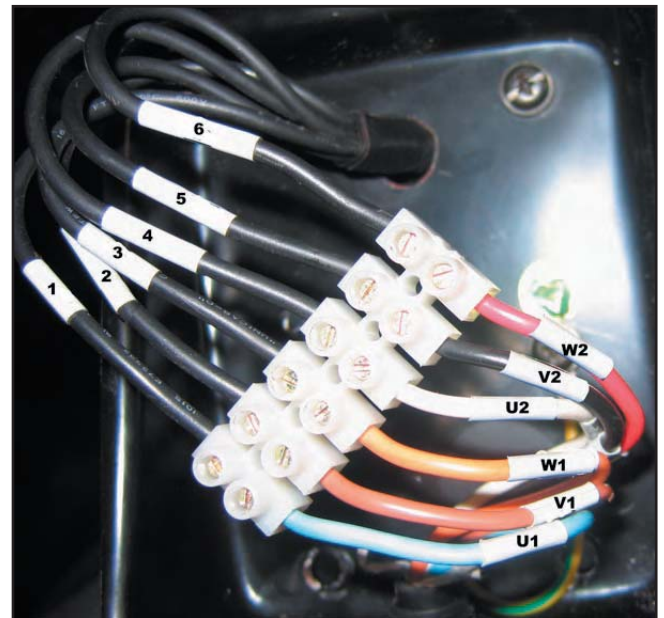

Figure 70. G0614 saw motor connection.



Electrical Components (G0614)

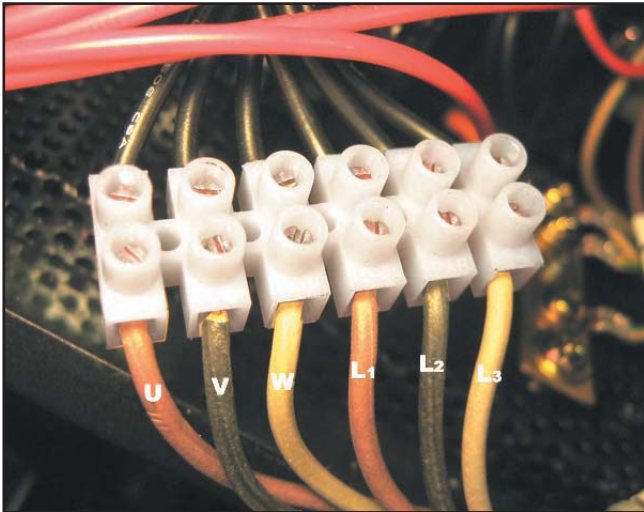

Figure 71. G0614 main junction.



Figure 72. G0614 blade stop limit switch.



G0613 110V/220V Single-Phase Wiring Diagram

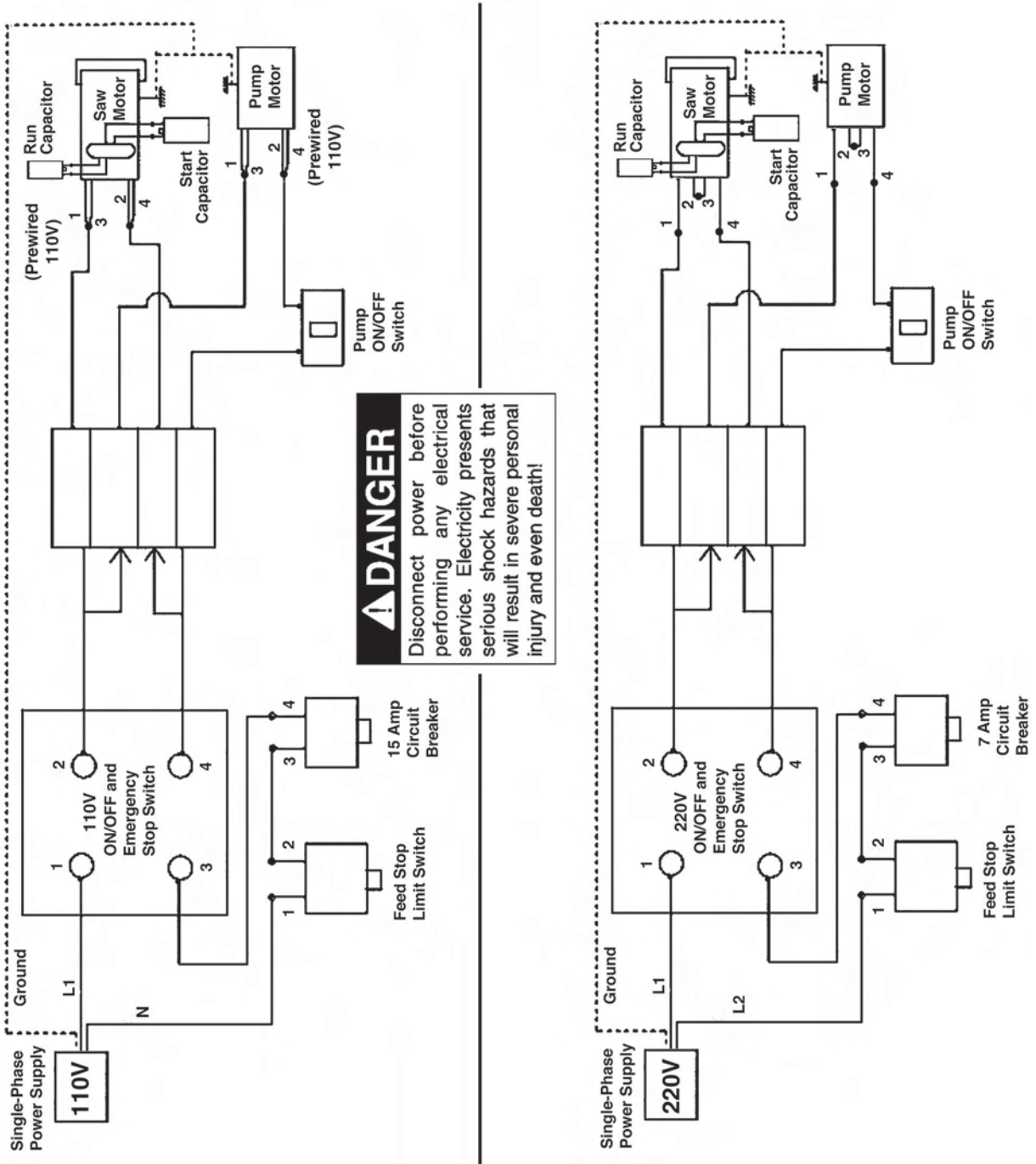

G0614 220V Three-Phase Wiring Diagram

⚠ DANGER
 Disconnect power before performing any electrical service. Electricity presents serious shock hazards that will result in severe personal injury and even death!

LEGEND
 KM1: Saw Motor Contactor Low Speed
 KM2: Saw Motor Contactor High Speed
 KM3: Pump Contactor
 KM4: Saw Motor Contactor
 FR1: Overload Relay
 FU1,2,3: Fuse
 PB1: ON Button
 PB2: OFF Button
 SQ2: Emergency Stop
 SQ3: Feed Stop Limit Switch
 SB3: Pump Relay
 SB4: Speed Switch

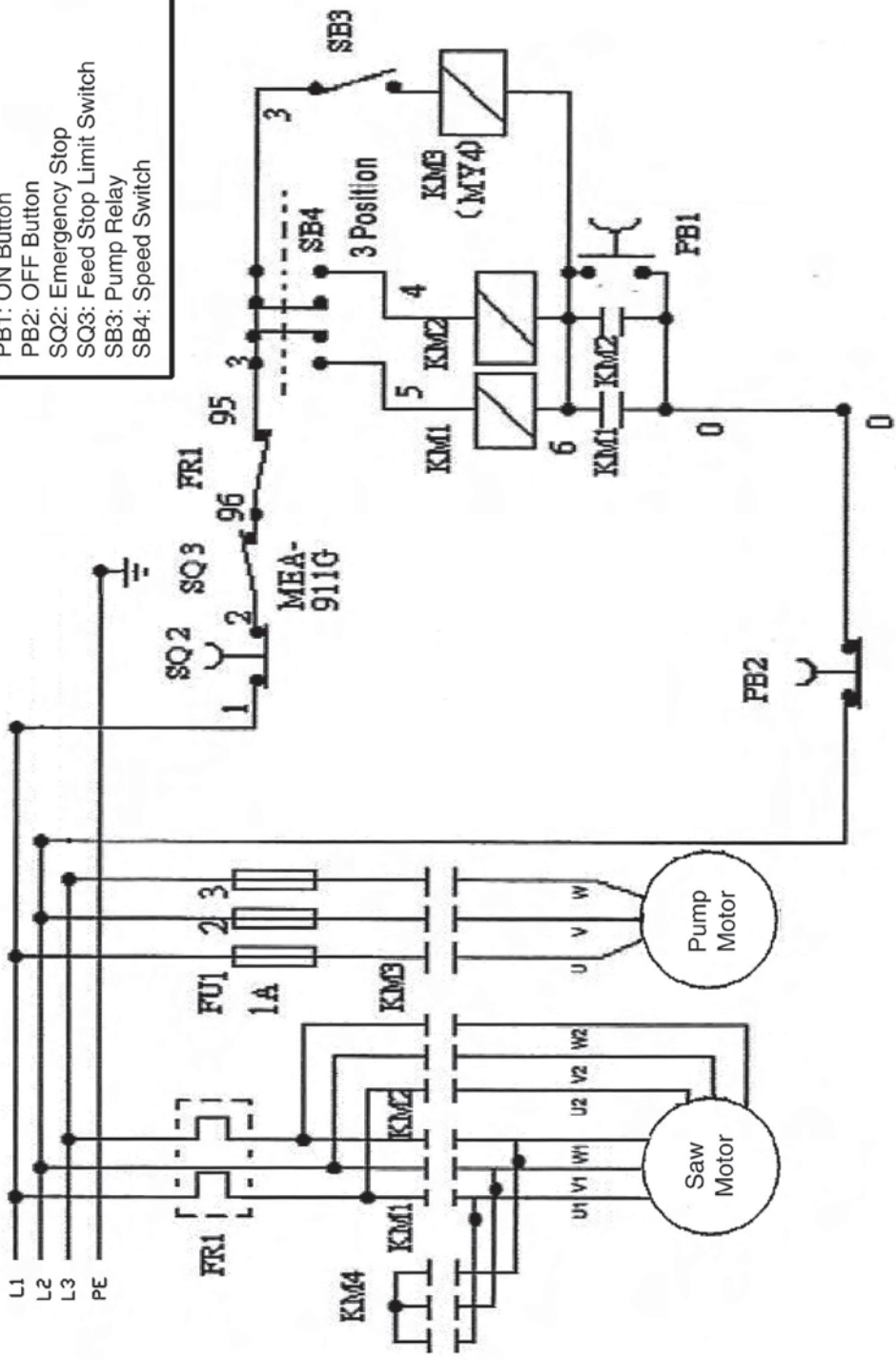

Headstock and Bow Breakdown (G0613)

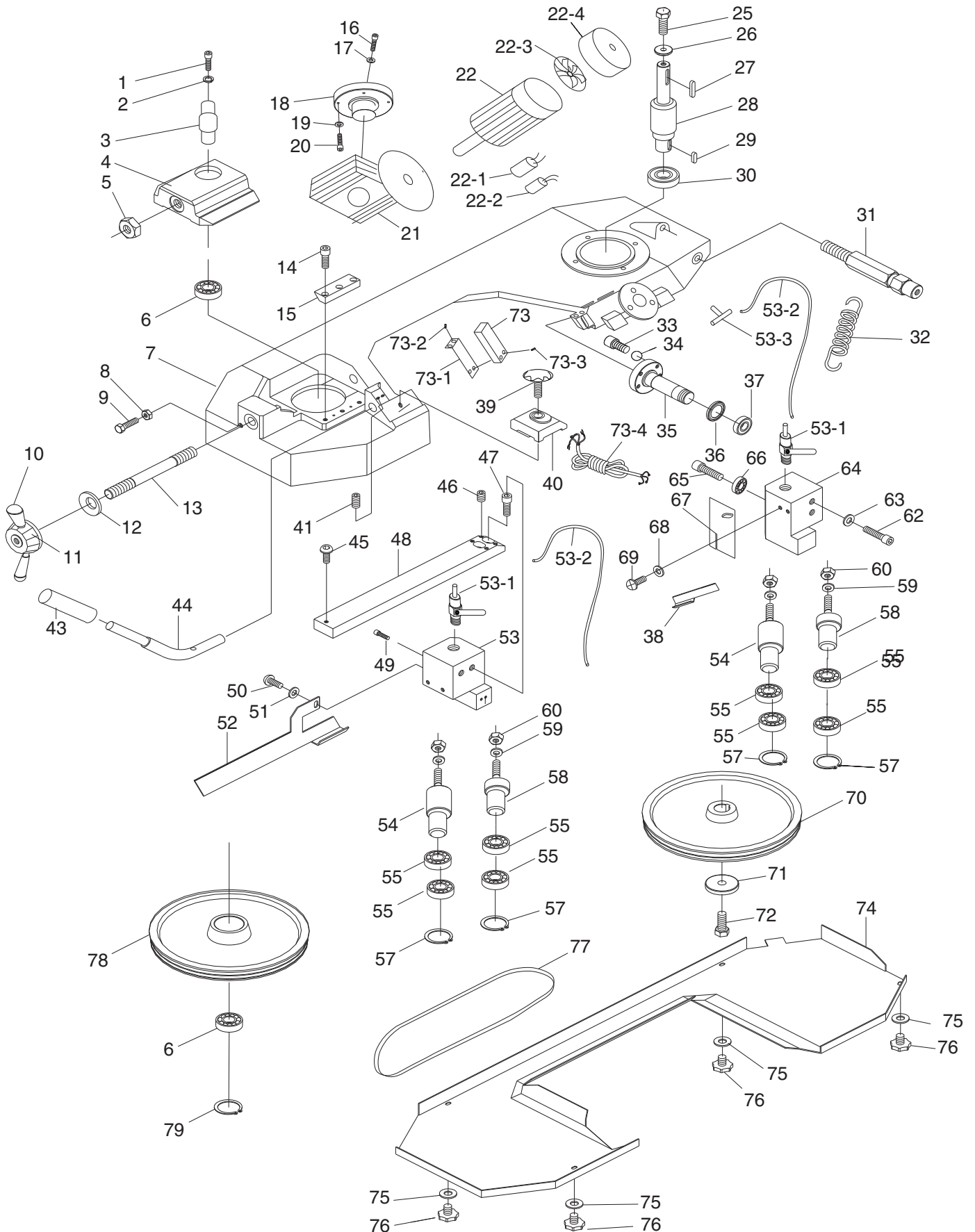

Parts List (G0613)

REF	PART #	DESCRIPTION
1	PSB64M	CAP SCREW M10-1.5 X 25
2	PW04M	FLAT WASHER 10MM
3	P0613003	SHAFT
4	P0613004	ANCHOR BLOCK
5	PN13M	HEX NUT M16-2
6	P6204	BALL BEARING 6204
7	P0613007	BODY FRAME
8	PN01M	HEX NUT M6-1
9	PB29M	HEX BOLT M6-1 X 30
10	P0613010	KNOB
11	P0613011	BLADE TENSION HANDLE
12	P0613012	CONCAVE WASHER
13	P0613013	LEADSCREW
14	PSB31M	CAP SCREW M8-1.25 X 25
15	P0613015	FIXED BLOCK
16	PSB13M	CAP SCREW M8-1.25 X 30
17	PLW04M	LOCK WASHER 8MM
18	P0613018	REDUCER BLOCK
19	PW01M	FLAT WASHER 8MM
20	PSB31M	CAP SCREW M8-1.25 X 25
21	P0613021	GEARBOX
22	P0613022	MOTOR 220V, SINGLE PHASE
22-1	P0613022-1	START CAPACITOR
22-2	P0613022-2	RUN CAPACITOR
22-3	P0613022-3	FAN
22-4	P0613022-4	FAN COVER
25	PB32M	HEX BOLT M10-1.5 X 25
26	PW04M	FLAT WASHER 10MM
27	P0613027	KEY 8 X 7 X 35
28	P0613028	OUTPUT SHAFT
29	PK109M	KEY 7 X 7 X 35
30	P6206	BALL BEARING 6206
31	P0613031	SPRING SUPPORT
32	P0613032	TENSION SPRING
33	PSB06M	CAP SCREW M6-1 X 25
34	PLW03M	LOCK WASHER 6MM
35	P0613035	FRAME PIVOT SHAFT
36	P0613036	CHIP COVER
37	P0613037	TAPERED BEARING 32006
38	P0613038	BLADE COVER(REAR)
39	P0613039	KNOB BOLT 3/8-24 X 1
40	P0613040	FIXED BLOCK
41	PSS06M	SET SCREW M8-1.25 X 16

REF	PART #	DESCRIPTION
43	P0613043	HANDLE
44	P0613044	HANDLE PIPE
45	PSBS05M	BUTTON HD CAP SCR M6-1 X 25
46	PSS20M	SET SCREW M8-1.25 X 8
47	PSB40M	CAP SCREW M8-1.25 X 35
48	P0613048	BLADE ADJUSTMENT BAR
49	PSB58M	CAP SCREW M8-1.25 X 12
50	PS09M	PHLP HD SCR M5-.8 X 10
51	PW02M	FLAT WASHER 5MM
52	P0613052	BLADE COVER (FRONT)
53	P0613053	ADJUSTMENT BLOCK (FRONT)
53-1	P0613053-1	FLOW VALVE
53-2	P0613053-2	COOLANT HOSE
53-3	P0613053-2	STEEL "T"
54	P0613054	ECCENTRIC GUIDE (L)
55	P608A	BALL BEARING 608
57	PR09M	EXT RETAINING RING 20MM
58	P0613058	ECCENTRIC GUIDE (R)
59	PLW04M	LOCK WASHER 8MM
60	PN03M	HEX NUT M8-1.25
62	PSB13M	CAP SCREW M8-1.25 X 30
63	PW01M	FLAT WASHER 8MM
64	P0613064	ADJUSTMENT BLOCK (REAR)
65	P4030007	PIN
66	P608A	BALL BEARING 608
67	P0613067	CHIP PLATE
68	PW02M	FLAT WASHER 5MM
69	PS09M	PHLP HD SCR M5-.8 X 10
70	P0613070	DRIVE WHEEL
71	PW04M	FLAT WASHER 10MM
72	PB32M	HEX BOLT M10-1.5 X 25
73	P0613073	WATERPROOF LIMIT SWITCH
73-1	P0613073-1	SWITCH BRACKET
73-2	PS09M	PHLP HD SCR M5-.8 X 10
73-3	PS75M	PHLP HD SCR M5-.8 X 35
73-4	P0613073-4	WATERPROOF POWER CORD
74	P0613074	MAIN BLADE COVER
75	PW03M	FLAT WASHER 6MM
76	P0613076	KNOB SCREW M6-1 X 10
77	P0613077	SAW BLADE
78	P0613078	IDLER WHEEL
79	PR11M	EXT RETAINING RING 25MM



Headstock and Bow Breakdown (G0614)

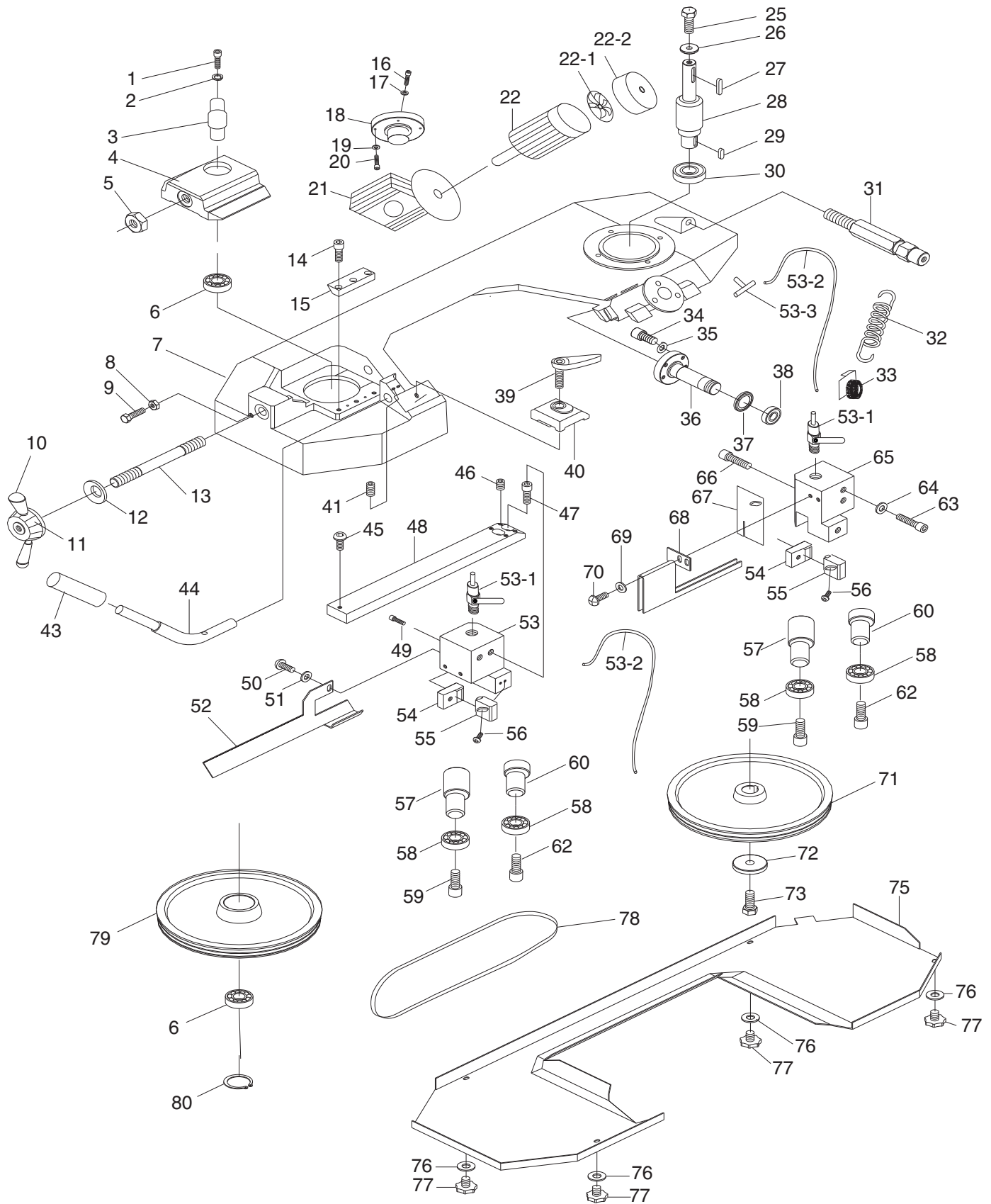

Parts List (G0614)

REF	PART #	DESCRIPTION
1	PSB64M	CAP SCREW M10-1.5 X 25
2	PW04M	FLAT WASHER 10MM
3	P0614003	SHAFT
4	P0614004	ANCHOR BLOCK
5	P0614005	HEX NUT M16-2
6	P6205	BALL BEARING 6205
7	P0614007	BODY FRAME
8	PN01M	HEX NUT M6-1
9	PB29M	HEX BOLT M6-1 X 30
10	P0614010	KNOB
11	P0614011	BLADE TENSION HANDLE
12	P0614012	CONCAVE WASHER
13	P0614013	LEADSCREW
14	P0614014	CAP SCREW M8-1.25 X 25L
15	P0614015	FIXED BLOCK
16	PSB13M	CAP SCREW M8-1.25 X 30
17	PLW04M	LOCK WASHER 8MM
18	P0614018	REDUCER BLOCK
19	PW01M	FLAT WASHER 8MM
20	PSB31M	CAP SCREW M8-1.25 X 25
21	P0614021	GEARBOX
22	P0614022	MOTOR 220V 3-PHASE
22-1	P0614022-1	FAN
22-2	P0614022-2	COVER
25	PB32M	HEX BOLT M10-1.5 X 25
26	PW04M	FLAT WASHER 10MM
27	P0614027	KEY 8 X 7 X 35
28	P0614028	OUTPUT SHAFT
29	PK109M	KEY 7 X 7 X 35
30	P6206	BALL BEARING 6206
31	P0614031	SPRING SUPPORT
32	P0614032	TENSION SPRING
33	P0614033	BRUSH
34	PSB06M	CAP SCREW M6-1 X 25
35	PLW03M	LOCK WASHER 6MM
36	P0614036	FRAME PIVOT SHAFT
37	P0614037	CHIP COVER
38	P0614038	TAPERED BEARING 32006
39	P0614039	LEVER BOLT 3/8-24 X 1
40	P0614040	FIXED BLOCK

REF	PART #	DESCRIPTION
41	PSS06M	SET SCREW M8-1.25 X 16
43	P0614043	HANDLE
44	P0614044	HANDLE PIPE
45	PSBS05M	BUTTON HD CAP SCR M6-1 X 20
46	PSS20M	SET SCREW M8-1.25 X 8
47	PSB40M	CAP SCREW M8-1.25 X 35
48	P0614048	BLADE ADJUSTMENT BAR
49	PSB58M	CAP SCREW M8-1.25 X 12
50	PS09M	PHLP HD SCR M5-.8 X 10
51	PW02M	FLAT WASHER 5MM
52	P0614052	BLADE COVER (FRONT)
53	P0614053	ADJUSTMENT BLOCK (FRONT)
53-1	P0614053-1	FLOW VALVE
53-2	P0613053-2	COOLANT HOSE
53-3	P0613053-2	STEEL "T"
54	P0614054	GUIDE
55	P0614055	GUIDE
56	PSBS05M	BUTTON HD CAP SCR M6-1 X 20
57	P0614057	ECCENTRIC GUIDE
58	P608A	BALL BEARING 608
59	PS22M	PHLP HD SCR M5-.8 X 25
60	P0614060	ECCENTRIC GUIDE
62	PSB10M	CAP SCR M5-.8 X 15
63	PSB40M	CAP SCREW M8-1.25 X 35
64	PLW04M	LOCK WASHER 8MM
65	P0614065	ADJUSTMENT BLOCK (REAR)
66	PSB58M	CAP SCREW M8-1.25 X 12
67	P0614067	CHIP PLATE
68	P0614068	BLADE COVER (REAR)
69	PW02M	FLAT WASHER 5MM
70	PS09M	PHLP HD SCR M5-.8 X 10
71	P0614071	DRIVE WHEEL
72	PW04M	FLAT WASHER 10MM
73	PB32M	HEX BOLT M10-1.5 X 25
75	P0614075	MAIN BLADE COVER
76	PW03M	FLAT WASHER 6MM
77	P0614077	KNOB SCREW M6-1 X 10
78	P0614078	SAW BLADE
79	P0614079	IDLER WHEEL
80	PR11M	EXT RETAINING RING 25MM



Base Breakdown (G0613)

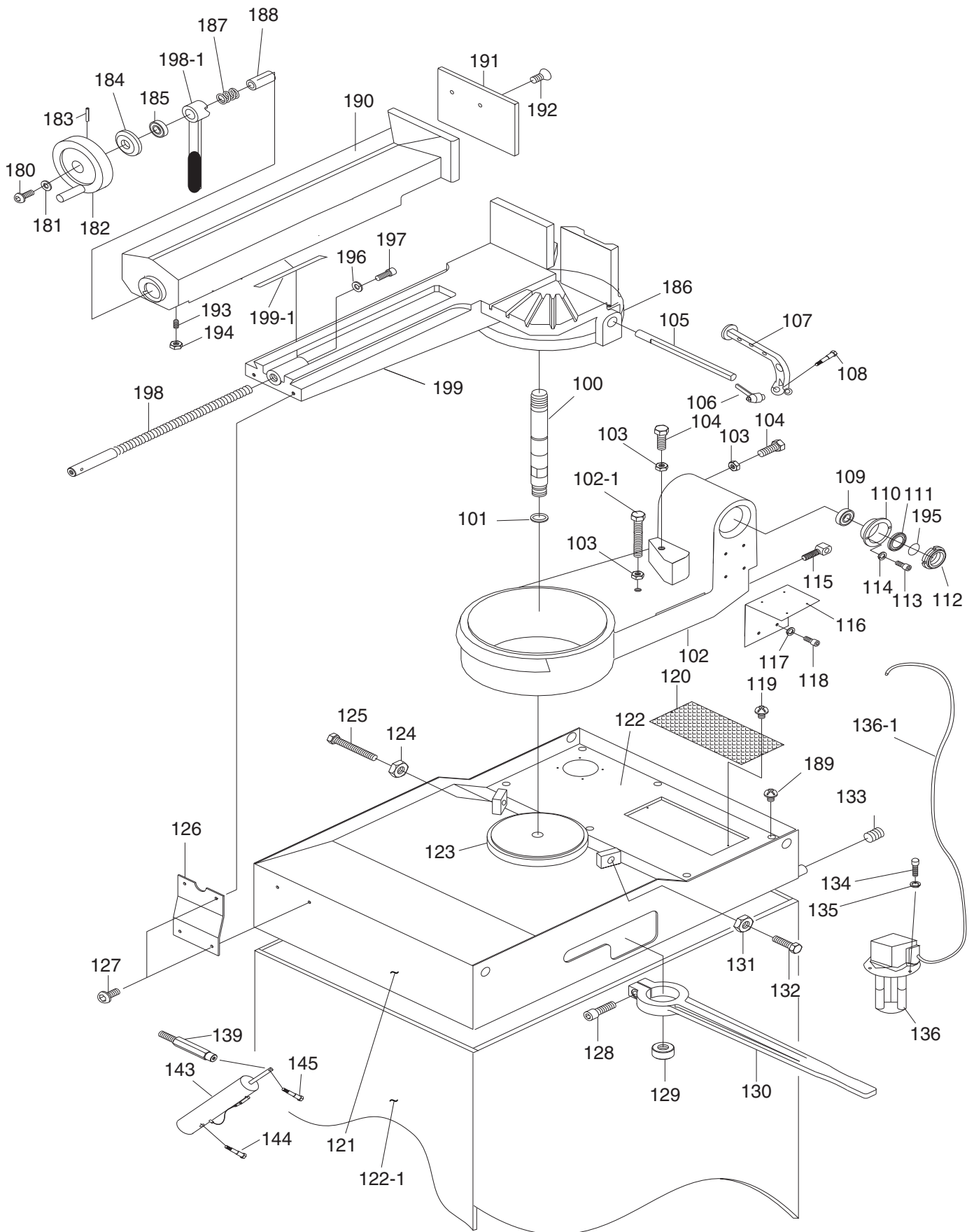

Parts List (G0613)

REF	PART #	DESCRIPTION
100	P0613100	WISE JAW ADJUSTABLE ROD
101	P0613101	RETAINER
102	P0613102	SWIVEL ARM
102-1	PB14M	HEX BOLT M10-1.5 X 35
103	PN02M	HEX NUT M10-1.5
104	PB01M	HEX BOLT M10-1.5 X 30
105	P0613105	DISTANCE SET ROD
106	P0613106	KNOB NUT M6-1
107	P0613107	BRACKET
108	PS26M	PHLP HD SCR M6-1 X 20
109	P0613109	BALL BEARING 32006
110	P0613110	BUSHING
111	P0613111	BEARING COVER
112	P0613112	SPANNER NUT M30 X 1.5
113	PSB01M	CAP SCREW M6-1 X 16
114	PLW03M	LOCK WASHER 6MM
115	P0613115	SPRING ANCHOR
116	P0613116	L-BRACKET
117	PLW04M	LOCK WASHER 8MM
118	PSB31M	CAP SCREW M8-1.25 X 25
119	PS05M	PHLP HD SCR M5-.8 X 8
120	P0613120	SCREEN
121	P0613121	BASE
121-1	P0613121-1	BASE CABINET
122	P0613122	COVER
123	P0613123	SWIVEL PLATE
124	PN02M	HEX NUT M10-1.5
125	PB01M	HEX BOLT M10-1.5 X 30
126	P0613126	FIXED PLATE
127	PSB115M	BUTTON HD CAP SCR M6-1 X 16
128	PSB84M	CAP SCREW M10-1.5 X 35
129	P0613129	NUT
130	P0613130	ADJUSTABLE HANDLE

REF	PART #	DESCRIPTION
131	PN02M	HEX NUT M10-1.5
132	PB01M	HEX BOLT M10-1.5 X 30
133	P0613133	HEX PLUG 3/8PT
134	PSB01M	CAP SCR M6-1 X 16
135	PLW03M	LOCK WASHER 6MM
136	P0613136	PUMP 110V, SINGLE PHASE
136-1	P0613136-1	COOLANT HOSE
139	P0613139	CYLINDER BRACKET
143	P0613143	CYLINDER
144	PSB124M	CAP SCREW M12-1.75 X 80
145	PSB90M	CAP SCREW M10-1.5 X 55
180	PSBS01M	BUTTON HD CAP SCR M8-1.25 X 20
181	PW01M	FLAT WASHER 8MM
182	P0613082	HANDWHEEL
183	P0613183	ROLL PIN
184	P0613084	BEARING COVER
185	P0613085	BALL BEARING 51106
186	P0613086	WISE BED
187	P0613087	TENSION SPRING
188	P0613088	BUSHING
189	PS11M	PHLP HD SCR M6-1 X 16
190	P0613090	WISE JAW BRACKET(FRONT)
191	P0613091	WISE PLATE
192	PFH23M	FLAT HD SCR M8-1.25 X 16
193	PSS09M	SET SCREW M8-1.25 X 20
194	PN03M	HEX NUT M8-1.25
195	P0613095	O-RING
196	PW01M	FLAT WASHER 8MM
197	PSB14M	CAP SCREW M8-1.25 X 20
198	P0613098	LEADSCREW A
198-1	P0613098-1	LEADSCREW LOCK LEVER
199	P0613099	WISE JAW BRACKET(REAR)
199-1	P0613099-1	GIB



Base Breakdown (G0614)

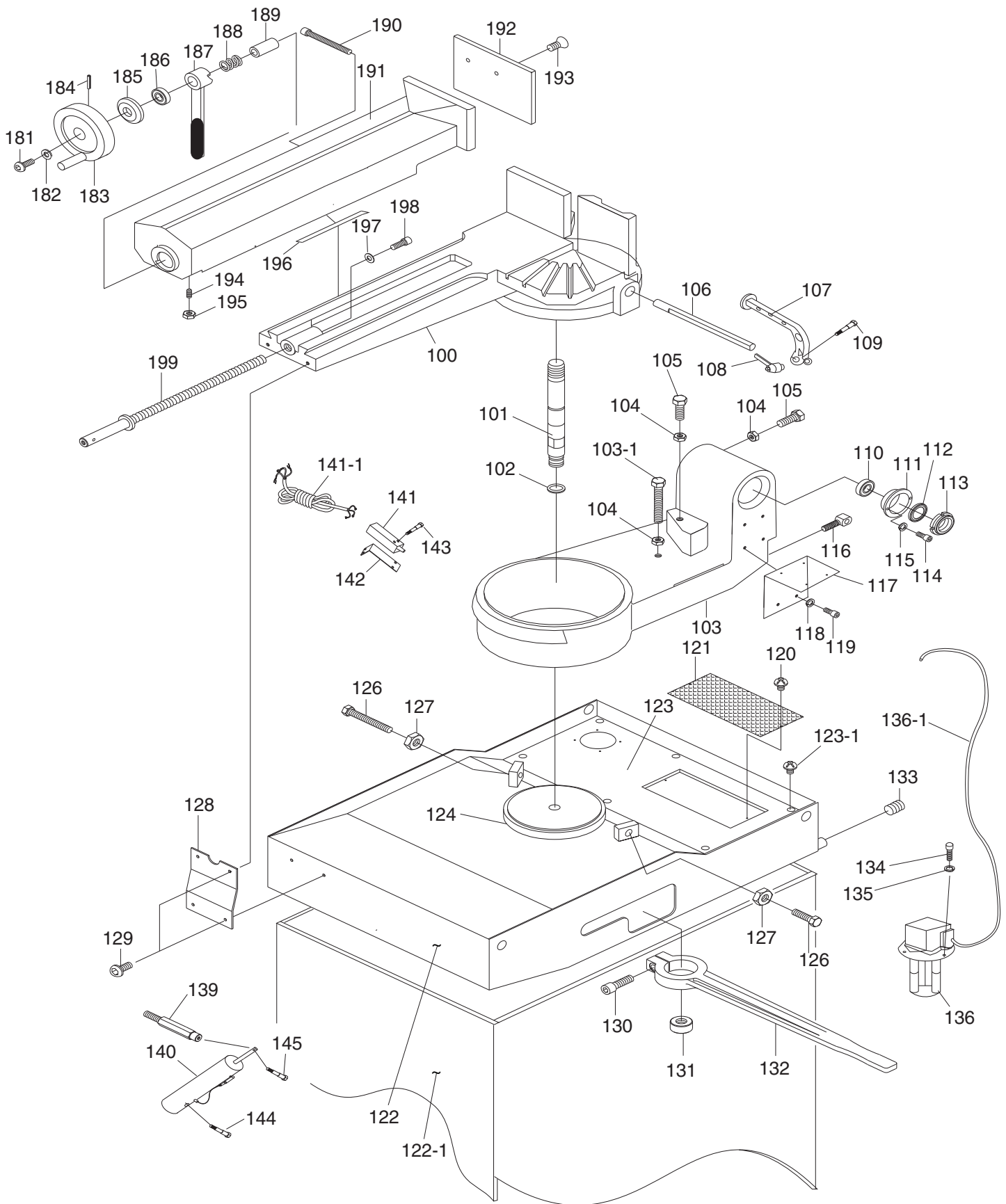

Parts List (G0614)

REF	PART #	DESCRIPTION
100	P0614100	WISE JAW BRACKET(REAR)
101	P0614101	WISE JAW ADJUSTABLE ROD
102	P0614102	RETAINER
103	P0614103	SWIVEL ARM
103-1	PB14M	HEX BOLT M10-1.5 X 35
104	PN02M	HEX NUT M10-1.5
105	PB01M	HEX BOLT M10-1.5 X 30
106	P0614106	DISTANCE SET ROD
107	P0614107	BRACKET
108	P0614108	LEVER
109	PS26M	PHLP HD SCR M6-1 X 20
110	P0614110	BALL BEARING 32006
111	P0614111	BUSHING
112	P0614112	BEARING COVER
113	P0614113	SPANNER NUT M30 X 1.5
114	PSB01M	CAP SCREW M6-1 X 16
115	PLW03M	LOCK WASHER 6MM
116	P0614116	SPRING ANCHOR
117	P0614117	L-BRACKET
118	PLW04M	LOCK WASHER 8MM
119	PSB31M	CAP SCREW M8-1.25 X 25
120	PS05M	PHLP HD SCR M5-.8 X 8
121	P0614121	SCREEN
122	P0614122	BASE
122-1	P0614122-1	BASE CABINET
123	P0614123	COVER
123-1	PS14M	PHLP HD SCR M6-1 X 12
124	P0614124	SWIVEL PLATE
126	PB01M	HEX BOLT M10-1.5 X 30
127	PN02M	HEX NUT M10-1.5
128	P0614128	FIXED PLATE
129	PSB115M	BUTTON HD CAP SCR M6-1 X 16
130	PSB84M	CAP SCREW M10-1.5 X 35

REF	PART #	DESCRIPTION
131	P0614131	NUT
132	P0614132	ADJUSTABLE HANDLE
133	P0614133	HEX PLUG 3/8PT
134	PSB01M	CAP SCR M6-1 X 16
135	PW03M	FLAT WASHER 6MM
136	P0614136	PUMP 220V, 3-PHASE
136-1	P0614136-1	PLASTIC TUBING
140	P0614140	CYLINDER
141	P0614141	WATERPROOF LIMIT SWITCH
141-1	P0614141-1	WATERPROOF POWER CORD
142	P0614142	SWITCH PLAQUE
143	PS75M	PHLP HD SCR M5-.8 X 35
144	PSB124M	CAP SCREW M12-1.75 X 80
145	PSB90M	CAP SCREW M10-1.5 X 55
181	PSBS01M	BUTTON HD CAP SCR M8-1.25 X 20
182	PW01M	FLAT WASHER 8MM
183	P0614083	WHEEL
184	PSS20M	ROLL PIN
185	P0614085	BEARING COVER
186	P0614086	BALL BEARING 51106
187	P0614087	WISE HANDLE
188	P0614088	TENSION SPRING
189	P0614089	BUSHING
190	PSB06M	CAP SCREW M6-1 X 25
191	P0614091	WISE JAW BRACKET(FRONT)
192	P0614092	WISE PLATE
193	PFH23M	FLAT HD SCR M8-1.25 X 16
194	PSS09M	SET SCREW M8-1.25 X 20
195	PN03M	HEX NUT M8-1.25
196	P0614096	GIB
197	PW01M	FLAT WASHER 8MM
198	PSB14M	CAP SCREW M8-1.25 X 20
199	P0614099	LEADSCREW A



Electrical Box Breakdown (G0613)

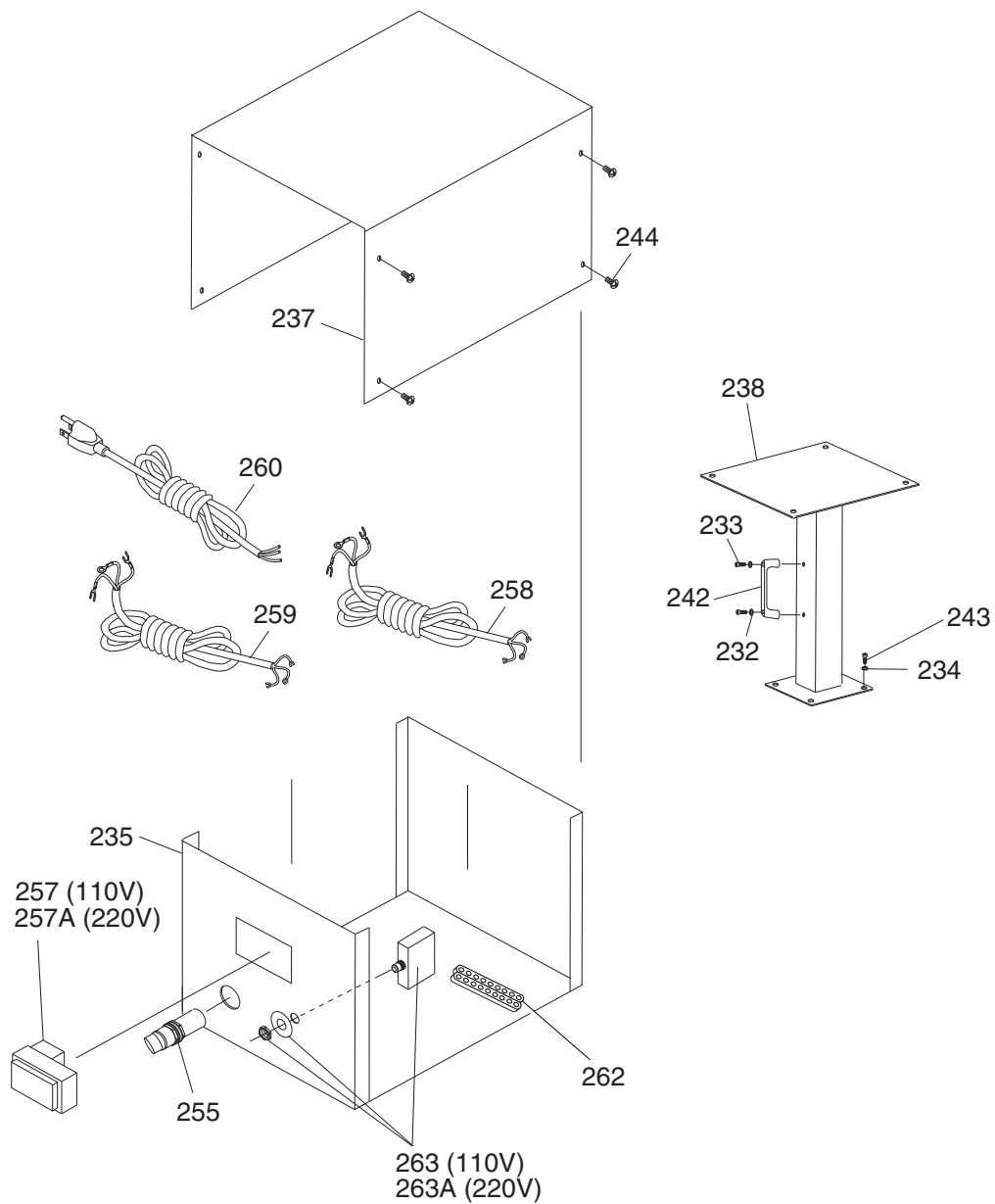

Parts List (G0613)

REF	PART #	DESCRIPTION
232	PLW03M	LOCK WASHER 6MM
233	PSB48M	CAP SCREW M6-1 X 35
234	PW01M	FLAT WASHER 8MM
235	P0613235	CONTROL BOX
237	P0613237	CONTROL BOX COVER
238	P0613238	CONTROL BOX STAND
242	P0613242	HANDLE
243	PSB14M	CAP SCREW M8-1.25 X 20
244	PS14M	PHLP HD SCR M6-1 X 12
255	P0613255	PUMP ROTARY SWITCH

REF	PART #	DESCRIPTION
257	P0613257	ON/OFF & EMGNCY SW 110V
257A	P0613257A	ON/OFF & EMGNCY SW 220V
258	P0613258	MOTOR POWER CORD 110V
259	P0613259	PUMP POWER CORD 110V
260	P0613260	POWER SUPPLY CORD 110V
262	P0613262	JUNCTION BLOCK
263	P0613263	CIRCUIT BREAKER 15A 110V
263A	P0613263A	CIRCUIT BREAKER 7A 220V
264	P0613264	220V CONVERSION KIT



Electrical Box Breakdown (G0614)

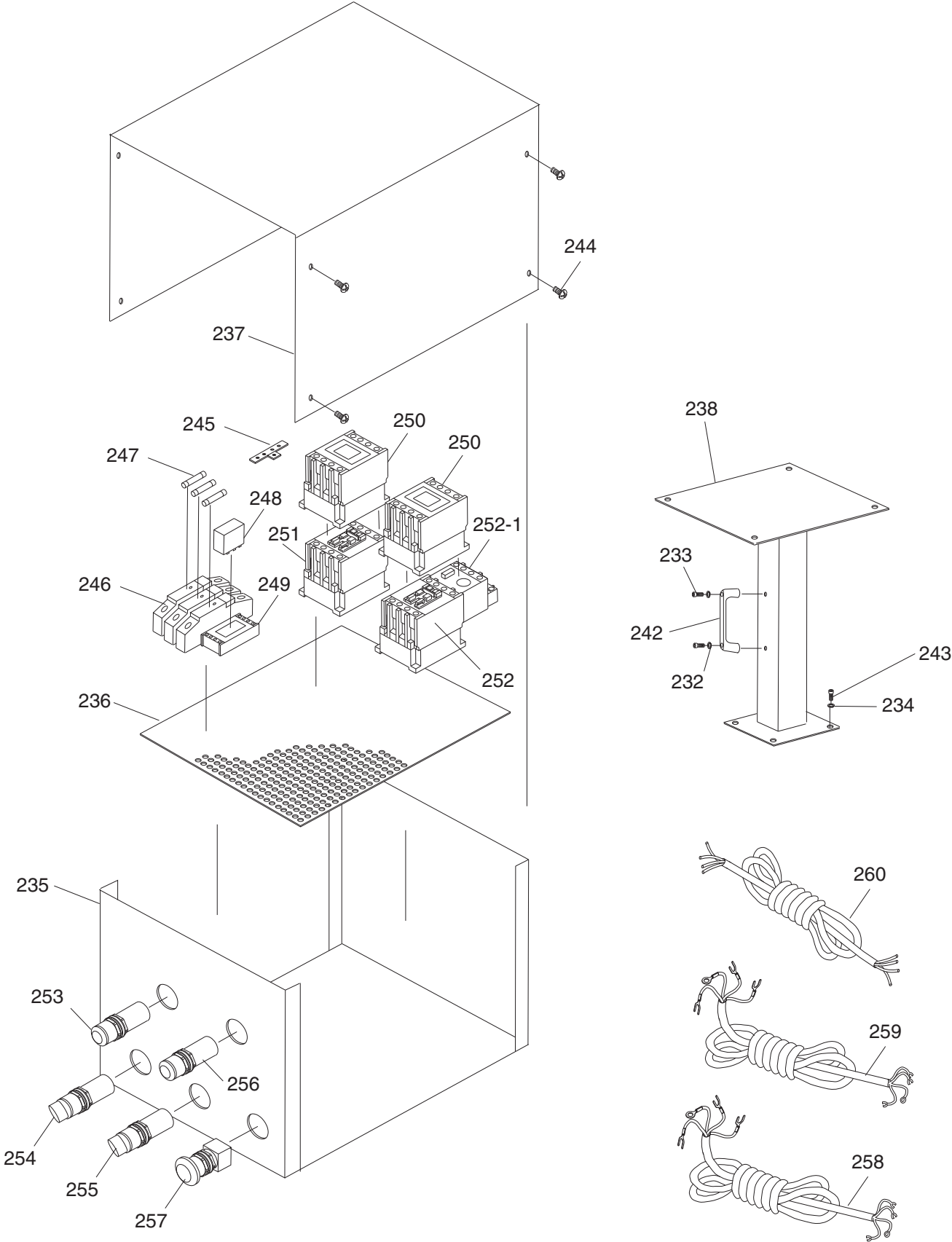

Parts List (G0614)

REF	PART #	DESCRIPTION
232	PLW03M	LOCK WASHER 6MM
233	PSB48M	CAP SCREW M6-1 X 35
234	PW01M	FLAT WASHER 8MM
235	P0614235	CONTROL BOX
236	P0614236	ELECTRICAL MOUNTING PLATE
237	P0614237	CONTROL BOX COVER
238	P0614238	CONTROL BOX STAND
242	P0614242	HANDLE
243	PSB14M	CAP SCREW M8-1.25 X 20
244	PS14M	PHLP HD SCR M6-1 X 12
245	P0614245	GROUND PLATE
246	P0614246	FUSE HOUSING
247	P0614247	FUSE
248	P0614248	RELAY RXL 4A06B1P7

REF	PART #	DESCRIPTION
249	P0614249	RELAY BASE
250	P0614250	CONTACTOR 220V, TCF-4
251	P0614251	CONTACTOR 220V, TC-11
250-1	P0614250	CONTACTOR 220V,TCF-4
252	P0614252	CONTACTOR 220V, TC-11
252-1	P0614252-1	THERMAL RELAY 220V, THR-12
253	P0614253	ON PUSHBUTTON
254	P0614254	MOTOR 2-SPEED SWITCH
255	P0614255	PUMP ROTARY SWITCH
256	P0614256	OFF PUSHBUTTON SWITCH
257	P0614257	EMERGENCY STOP SWITCH
258	P0614258	MOTOR POWER CORD 3-PHASE
259	P0614259	PUMP POWER CORD 3-PHASE
260	P0614260	POWER SUPPLY CORD 3-PHASE



Cabinet and Gearbox Breakdown (G0613 & G01614)

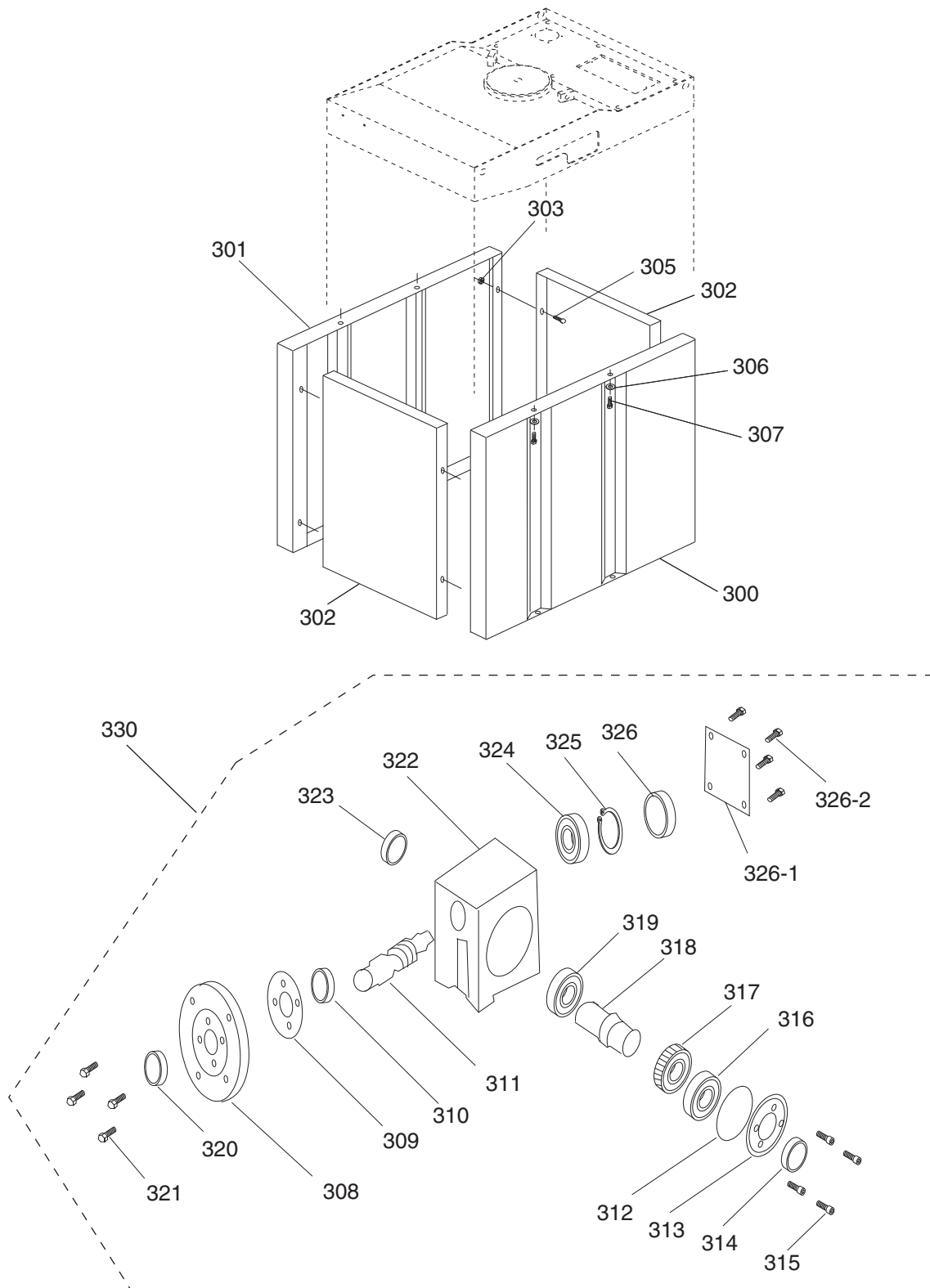

Parts List (G0613)

REF	PART #	DESCRIPTION
300	P0613300	FRONT PANEL
301	P0613301	REAR PANEL
302	P0613302	SIDE PANEL
303	PN02	HEX NUT 5/16-18
304	PW01M	FLAT WASHER 8MM
305	PCB01	CARRIAGE BOLT 5/16-18 X 5/8
306	PW04M	FLAT WASHER 10MM
307	PB32M	HEX BOLT M10-1.5 X 25
308	P0613308	MOTOR FLANGE
309	P0613309	O-RING
310	P6006	BALL BEARING 6006ZZ
311	P0613311	WORM SHAFT
312	P0613312	O-RING
313	P0613313	OUTPUT SHAFT COVER
314	P0613314	OIL SEAL

REF	PART #	DESCRIPTION
315	PSB02M	CAP SCREW M6-1 X 20
316	P6008	BALL BEARING 6008
317	P0613317	WORM WHEEL
318	P0613318	OUTPUT SHAFT
319	P6008	BALL BEARING 6008
320	P0613320	OIL SEAL
321	PB10M	HEX BOLT M6-1 X 25
322	P0613322	HOUSING
323	P0613323	OIL SEAL
324	P6204	BALL BEARING 6204ZZ
325	PR79M	EXT RETAINING RING 47MM
326	P0613326	OIL SEAL
326-1	P0613326-1	OIL SEAL COVER
326-2	PB51	HEX BOLT 1/4-20 X 3/8
330	P0613330	COMPLETE GEARBOX

Parts List (G0614)

REF	PART #	DESCRIPTION
300	P0614300	FRONT PANEL
301	P0614301	REAR PANEL
302	P0614302	SIDE PANEL
303	PN02	HEX NUT 5/16-18
305	PCB01	CARRIAGE BOLT 5/16-18 X 5/8
306	PW04M	FLAT WASHER 10MM
307	PB32M	HEX BOLT M10-1.5 X 25
308	P0614308	MOTOR FLANGE
309	P0614309	O-RING
310	P6006	BALL BEARING 6006ZZ
311	P0614311	WORM SHAFT
312	P0614312	O-RING
313	P0614313	OUTPUT SHAFT COVER
314	P0614314	OIL SEAL
315	PSB02M	CAP SCREW M6-1 X 20

REF	PART #	DESCRIPTION
316	P6008	BALL BEARING 6008
317	P0614317	WORM WHEEL
318	P0614318	OUTPUT SHAFT
319	P6008	BALL BEARING 6008
320	P0614320	OIL SEAL
321	PB10M	HEX BOLT M6-1 X 25
322	P0614322	HOUSING
323	P0614323	OIL SEAL
324	P6204	BALL BEARING 6204ZZ
325	PR79M	EXT RETAINING RING 47MM
326	P0614326	OIL SEAL
326-1	P0614326-1	OIL SEAL COVER
326-2	PB51	HEX BOLT 1/4-20 X 3/8
330	P0614330	COMPLETE GEARBOX



Labels and Placement

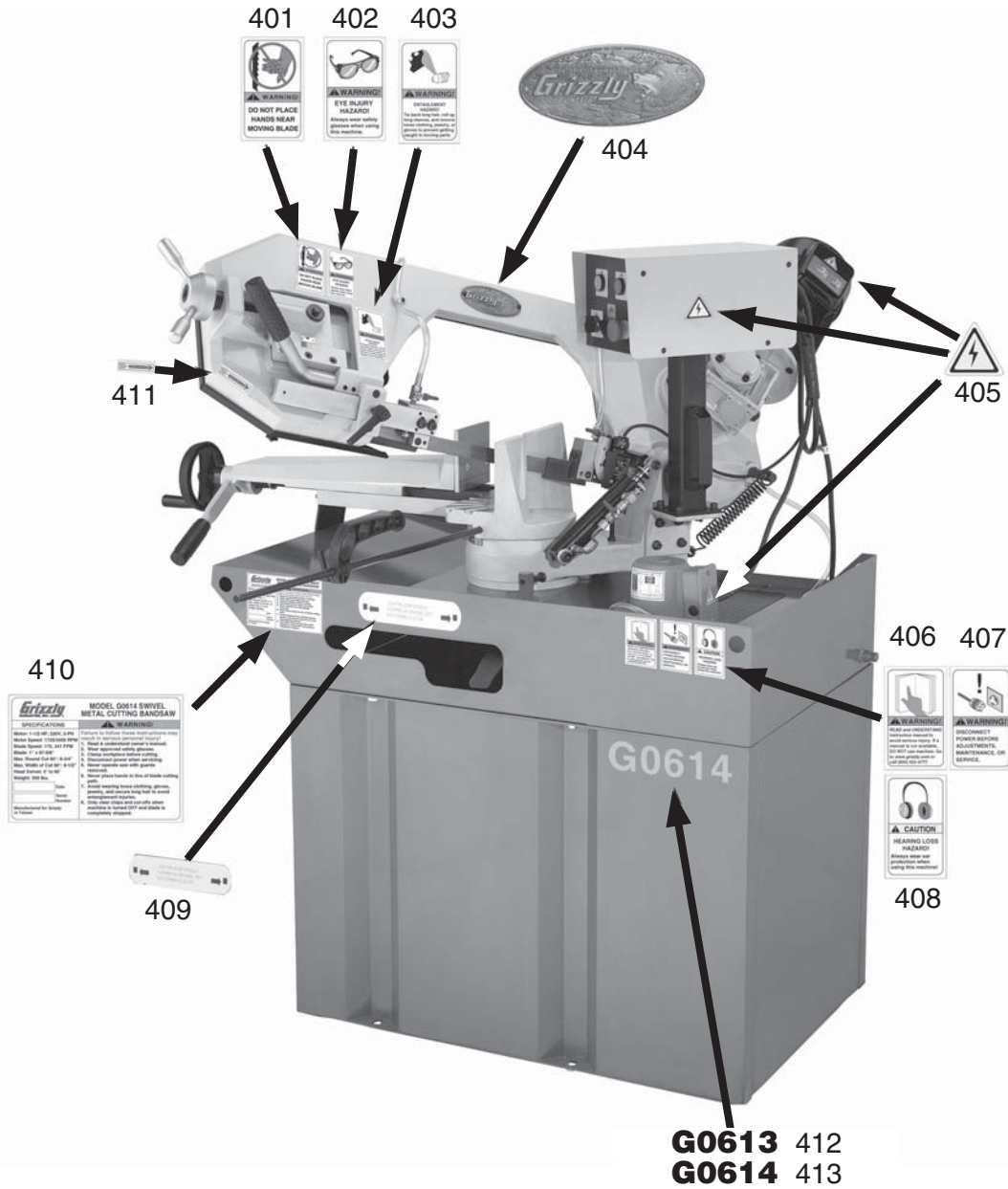

REF	PART #	DESCRIPTION
401	P0613401	FINGERS CUT WARNING LABEL
402	PLABEL-11	WEAR SAFETY GLASSES LABEL
403	P0613403	ENTANGLEMENT LABEL
404	P0613404	GRIZZLY LOGO PLATE
405	PLABEL-14	ELECTRICITY LABEL
406	PLABEL-12A	READ MANUAL LABEL
407	PLABEL-36	UNPLUG 220V LABEL

REF	PART #	DESCRIPTION
408	PLABEL-15	HEARING PROTECTION LABEL
409	P0613409	LOCK AND UNLOCK LABEL
410	P0613410	G0613 DATA LABEL
410	P0614410	G0614 DATA LABEL
411	P0613411	BLADE DIRECTION LABEL
412	P0613412	MODEL NUMBER LABEL (G0613)
413	P0614413	MODEL NUMBER LABEL (G0614)

⚠️ WARNING

Safety labels warn about machine hazards and ways to prevent injury. The owner of this machine **MUST** maintain the original location and readability of the labels on the machine. If any label is removed or becomes unreadable, **REPLACE** that label before using the machine again. Contact Grizzly at (800) 523-4777 or www.grizzly.com to order new labels.



WARRANTY AND RETURNS

Grizzly Industrial, Inc. warrants every product it sells for a period of **1 year** to the original purchaser from the date of purchase. This warranty does not apply to defects due directly or indirectly to misuse, abuse, negligence, accidents, repairs or alterations or lack of maintenance. This is Grizzly's sole written warranty and any and all warranties that may be implied by law, including any merchantability or fitness, for any particular purpose, are hereby limited to the duration of this written warranty. We do not warrant or represent that the merchandise complies with the provisions of any law or acts unless the manufacturer so warrants. In no event shall Grizzly's liability under this warranty exceed the purchase price paid for the product and any legal actions brought against Grizzly shall be tried in the State of Washington, County of Whatcom.

We shall in no event be liable for death, injuries to persons or property or for incidental, contingent, special, or consequential damages arising from the use of our products.

To take advantage of this warranty, contact us by mail or phone and give us all the details. We will then issue you a "Return Number," which must be clearly posted on the outside as well as the inside of the carton. We will not accept any item back without this number. Proof of purchase must accompany the merchandise.

The manufacturers reserve the right to change specifications at any time because they constantly strive to achieve better quality equipment. We make every effort to ensure that our products meet high quality and durability standards and we hope you never need to use this warranty.

Please feel free to write or call us if you have any questions about the machine or the manual.

Thank you again for your business and continued support. We hope to serve you again soon.





WARRANTY CARD

Name _____
 Street _____
 City _____ State _____ Zip _____
 Phone # _____ Email _____ Invoice # _____
 Model # _____ Order # _____ Serial # _____

The following information is given on a voluntary basis. It will be used for marketing purposes to help us develop better products and services. **Of course, all information is strictly confidential.**

1. How did you learn about us?

Advertisement Friend Catalog
 Card Deck Website Other:

2. Which of the following magazines do you subscribe to?

<input type="checkbox"/> Cabinet Maker	<input type="checkbox"/> Popular Mechanics	<input type="checkbox"/> Today's Homeowner
<input type="checkbox"/> Family Handyman	<input type="checkbox"/> Popular Science	<input type="checkbox"/> Wood
<input type="checkbox"/> Hand Loader	<input type="checkbox"/> Popular Woodworking	<input type="checkbox"/> Wooden Boat
<input type="checkbox"/> Handy	<input type="checkbox"/> Practical Homeowner	<input type="checkbox"/> Woodshop News
<input type="checkbox"/> Home Shop Machinist	<input type="checkbox"/> Precision Shooter	<input type="checkbox"/> Woodsmith
<input type="checkbox"/> Journal of Light Cont.	<input type="checkbox"/> Projects in Metal	<input type="checkbox"/> Woodwork
<input type="checkbox"/> Live Steam	<input type="checkbox"/> RC Modeler	<input type="checkbox"/> Woodworker West
<input type="checkbox"/> Model Airplane News	<input type="checkbox"/> Rifle	<input type="checkbox"/> Woodworker's Journal
<input type="checkbox"/> Modeltec	<input type="checkbox"/> Shop Notes	<input type="checkbox"/> Other:
<input type="checkbox"/> Old House Journal	<input type="checkbox"/> Shotgun News	

3. What is your annual household income?

\$20,000-\$29,000 \$30,000-\$39,000 \$40,000-\$49,000
 \$50,000-\$59,000 \$60,000-\$69,000 \$70,000+

4. What is your age group?

20-29 30-39 40-49
 50-59 60-69 70+

5. How long have you been a woodworker/metalworker?

0-2 Years 2-8 Years 8-20 Years 20+ Years

6. How many of your machines or tools are Grizzly?

0-2 3-5 6-9 10+

7. Do you think your machine represents a good value? Yes No

8. Would you recommend Grizzly Industrial to a friend? Yes No

9. Would you allow us to use your name as a reference for Grizzly customers in your area?
Note: We never use names more than 3 times. Yes No

10. Comments: _____

CUT ALONG DOTTED LINE

FOLD ALONG DOTTED LINE



Place
Stamp
Here



GRIZZLY INDUSTRIAL, INC.
P.O. BOX 2069
BELLINGHAM, WA 98227-2069



FOLD ALONG DOTTED LINE

Send a Grizzly Catalog to a friend:

Name _____
Street _____
City _____ State _____ Zip _____

TAPE ALONG EDGES--PLEASE DO NOT STAPLE

grizzly.com

TOOL WEBSITE

Buy Direct and Save with Grizzly® – Trusted, Proven and a Great Value!

*Visit Our Website Today And Discover
Why Grizzly® Is The Industry Leader!*

- SECURE ORDERING
- ORDERS SHIPPED WITHIN 24 HOURS
- E-MAIL RESPONSE WITHIN ONE HOUR

-OR-

Call Today For A **FREE**
Full Color Catalog

1-800-523-4777

